

# MULTIMAX L-ION PORTABLE FIRE EXTINGUISHERS

## PRODUCT OVERVIEW

MultiMax L-ion is a breakthrough, next generation fire extinguisher engineered to deliver comprehensive protection against diverse fire classes, including Class A, Class B, Class C, Electrically Started Fires, and Class F. MultiMax is rigorously tested and certified under NTA 8133, BSI Kitemarked, and CE standards, guaranteeing compliance with international and national safety benchmarks. Engineered for industrial, commercial, and residential environments, it combines durability, superior extinguishing performance, and operator safety into one versatile solution.



## FIRE CLASS COVERAGE



**Class A:** Solid combustibles such as paper, wood, fabric, and furniture.



**Class B:** Flammable liquids like petrol, diesel, kerosene, paints, and solvents.



**Class C\*:** Combustible gases such as LPG, propane, and methane.



**Class ESF:** Fires arising from energized electrical equipment, short circuits, and panels.



**Class F:** Cooking oil fires in hotel kitchens and staff cafeterias.

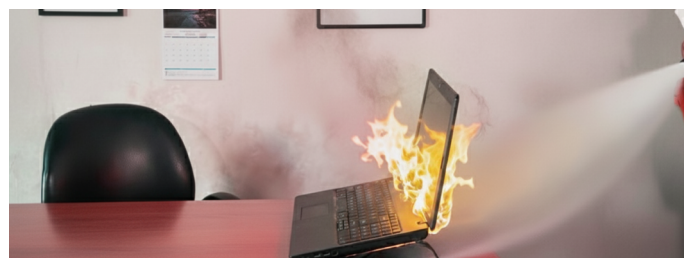

**Li-ion Battery Fires:** In phones, laptops, medical devices, and EV charging zones.



\*Tested for Class C Fire as per Australian Standard [AS/NZS 1850:2009].

**ENGINEERING DRAWINGS**

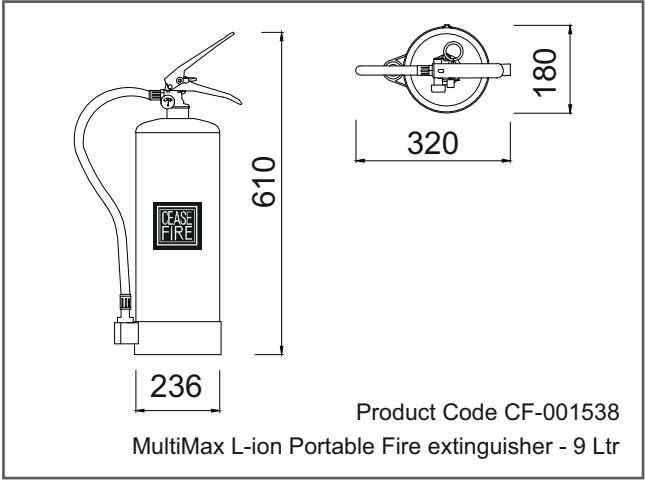
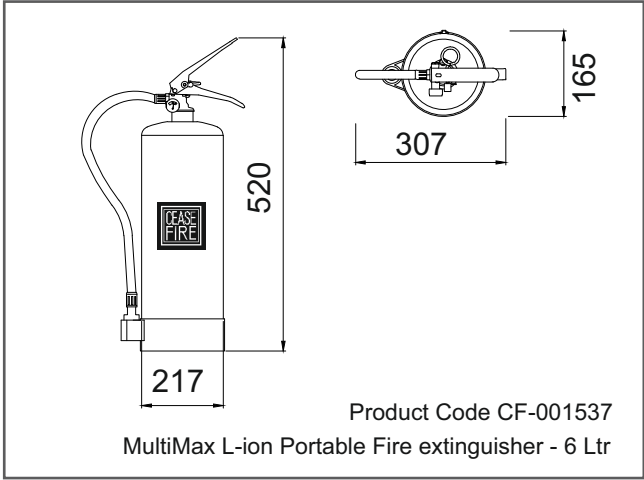
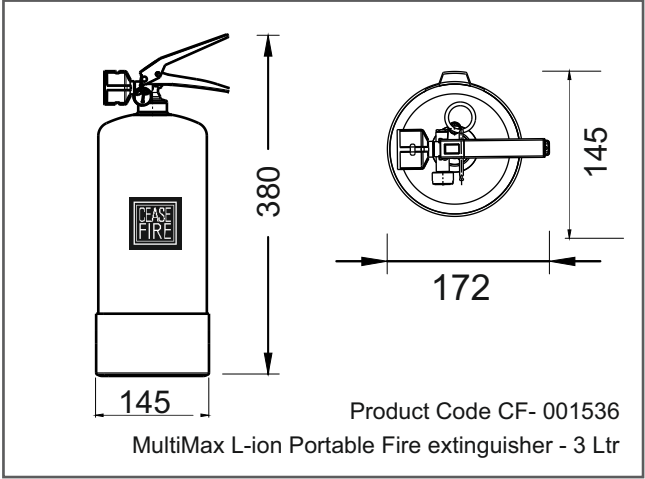
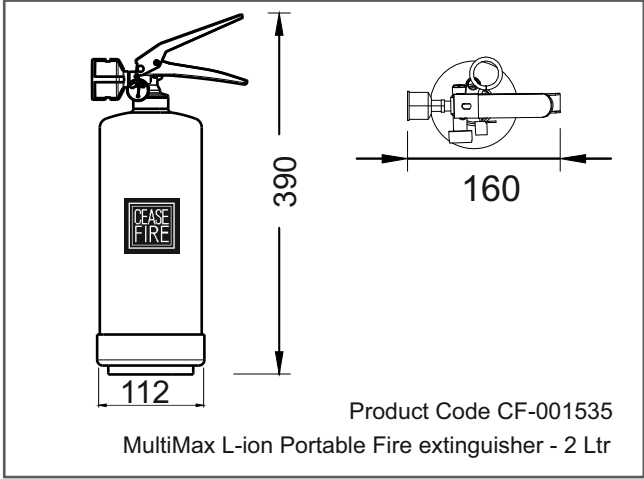
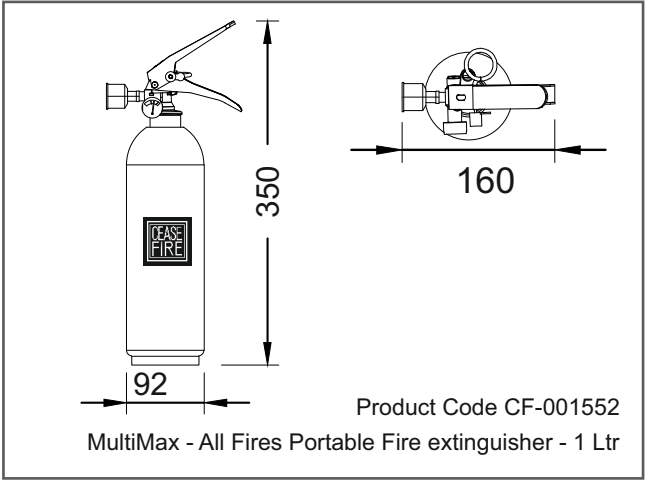
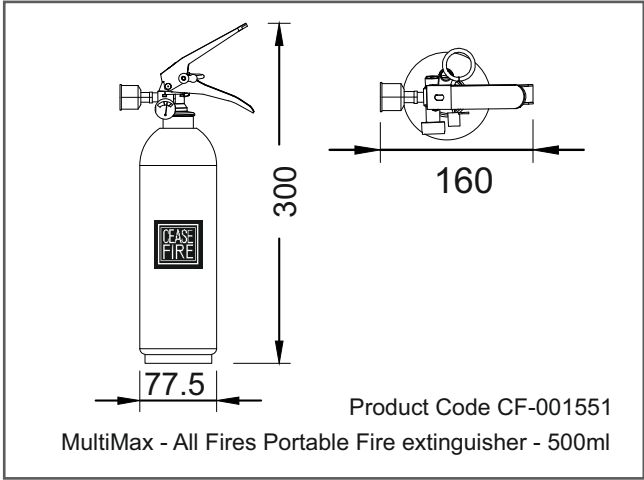





Product Code	UOM	CF-001551	CF-001552	CF-001535	CF-001536	CF-001537	CF-001538
Type of Dis. Fitting & Length	mm	Nozzle (Spray Type)	Nozzle (Spray Type)	Nozzle (Spray Type)	Nozzle (Spray Type)	EPDM Rubber Braided Hose Pipe with nozzle (Spray Type) Length of Hose (Flexible Section) - 410	EPDM Rubber Braided Hose Pipe with nozzle (Spray Type) Length of Hose (Flexible Section) - 480
Valve	Sec.	Nickle Coated Brass	Nickle Coated Brass	Nickle Coated Brass	Nickle Coated Brass	Nickle Coated Brass	Nickle Coated Brass
Valve Safety	Sec.	Pressure Relief Valve	Pressure Relief Valve	Pressure Relief Valve	Pressure Relief Valve	Pressure Relief Valve	Pressure Relief Valve
Average discharge duration as per BS EN 3-7:2004+A1:2007, clause 71.2	Sec.	10.5*	11.5*	12.5	13.5	28	40
Throw up to (approx.)	meter	2	2	5	5	6	6
Fire Rating to EN 3-7	—	1A**, 8B, F**	2A**, 13B, 5F	8A, 34B, 5F	8A, 55B, 25F	21A, 144B, 40F	27A, 183B, 40F
Battery Rating to NTA 8133	Wh	-	-	-	-	600	600
Operating Temperature Range	°C	+5 to +60	+5 to +60	+5 to +60	+5 to +60	+5 to +60	+5 to +60
Applicable to Type of Fire	—	Class A, B, C***, ESF, F & Li-Battery	Class A, B, C***, ESF, F & Li-Battery	Class A, B, C***, ESF, F & Li-Battery	Class A, B, C***, ESF, F & Li-Battery	Class A, B, C***, ESF, F & Li-Battery	Class A, B, C***, ESF, F & Li-Battery
Gross Weight (approx.)****	Kg	1.5	1.98	3.65	5.00	9.40	13.40
Product Warranty	Year	5	5	5	5	5	5

\*As per in-house testing.

\*\*Derated.

\*\*\*Tested for Class C Fire as per Australian Standard (AS/NZS 1850:2009).

\*\*\*\*It includes Empty Extinguisher, Contents, Plastic Base, Hose / Horn and bracket.

### CERTIFICATIONS



PRODUCT PICTURES



\*v1' Published Date is 27-04-2026.

\*\*Regular R&D and product improvisations may lead to change in product specifications in this data sheet, without any prior notice.

CEASEFIRE INDUSTRIES UK LIMITED

Call us at: 0-113-868-6666, 0-126-891-9999

www.ceasefire.co.uk