

FLUORINE FREE FOAM MIST BASED PORTABLE EXTINGUISHER

PRODUCT OVERVIEW

Ceasefire Fluorine Free Foam Mist extinguishers are next-gen extinguishers engineered for modern spaces, delivering high-performance firefighting using advanced fluorine-free foam mist technology, combining effective fire suppression with a strong commitment to environmental responsibility.

These extinguishers are developed without fluorinated chemicals such as PFOA and PFAS, making them a safer and more sustainable alternative to conventional foam extinguishers. The advanced foam mist discharge creates a fine blanket of foam droplets that rapidly suppress flames, cool surfaces, and seal the fuel source to help prevent re-ignition while ensuring controlled, low-visibility firefighting.

Designed for modern environments, Fluorine Free Foam Mist extinguishers are suitable for Class A, Class B, electrically started fires, and Class F cooking oil fires. Its spray-based discharge enables controlled application, ensuring safe use even in occupied and enclosed spaces without excessive disruption or visibility impairment.



ENGINEERING DRAWINGS

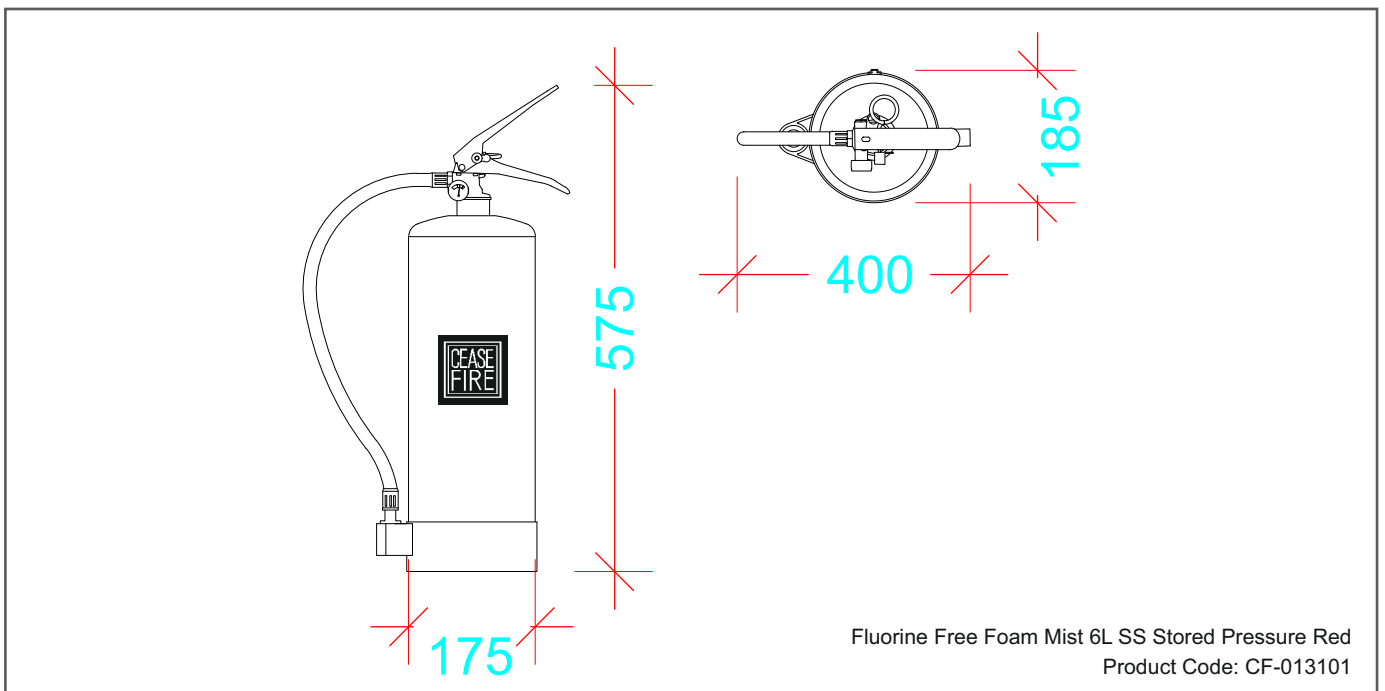



TECHNICAL SPECIFICATIONS		
Product Code	UOM	CF-013101
Description	—	Fire Extinguisher Fluorine Free Foam Mist 6L SS Stored Pressure Red
Capacity of Agent	L	6
Filling Tolerance By Volume	%	+5
Agent	—	Water + Fluorine Free Foam 6%
Certification Standard	—	IS-15683 PED
Diameter of Shell (approx.)	mm	175
Total Height (approx.)	mm	575
MOC of Shell	—	SS 304 (1.4301)
Min. Wall Thickness	mm	1.5
Test Pressure	Bar	35
Anti-Corrosive Treatment External	—	Outer surfaces were EP Powder coated having Thickness 50 Micron Min. RAL Shade 3000
Service Pressure	Bar	15
Type of Operating Mechanism	—	Squeeze Grip
Type of Pressure Gauge	—	Magnetic Bourdon Tube Type
Type of Dis. Fitting & Length	mm	EPDM Rubber Braided Hose Pipe with nozzle Length of Hose 500 mm (Min.)
Minimum Throw Distance (BRD as per IS-15683)	Meter	> 2
Min. Discharge Time (as per IS-15683)	Sec.	15
Fire Rating	—	3A 113B 75F
Operating Temperature Range	°C	From +5 to +60
Applicable to Type of Fire	—	A, B, F & Electrical Started Fire.
Gross Weight*	Kg	10.30 to 10.90
Product Warranty**	Year	9

*It includes Empty Extinguisher, Contents, Plastic Base, Hose / Horn and bracket.

**The warranty is subject to the terms and conditions mentioned on the warranty card.

CERTIFICATIONS

<p>IS: 15683 CM/L-8886112</p>	<p> 1128</p>	<p> 9001</p>
--	------------------	------------------

PRODUCT PICTURES



6 L

*v3' Published Date is 28-04-2025.

**Regular R&D and product improvisations may lead to change in product specifications in this data sheet, without any prior notice.