

## IN-PANEL TUBE BASED SUPPRESSION SYSTEM (CQRS)

### PRODUCT OVERVIEW

Research shows that most fires start with a spark in electrical mains, in the wiring in the server, in a genset, or deep in an automobile engine or industrial machinery. And by the time you notice the fire and can take action, it's too late because the fire has already destroyed everything inside.

These are perhaps the most dangerous of all fires. And there's just one-way to deal with them: instant detection and swift firefighting. But how do you detect a fire you cannot even see? And even if it is detected, how do you effectively fight it in an area that is difficult to access?



Ceasefire's In-Panel Tube-Based System (CQRS) is a revolutionary firefighting solution that combines ground-breaking technology with functional simplicity to keep what's precious safe.

### Based on two agent explosion technologies, CQRS is available as:

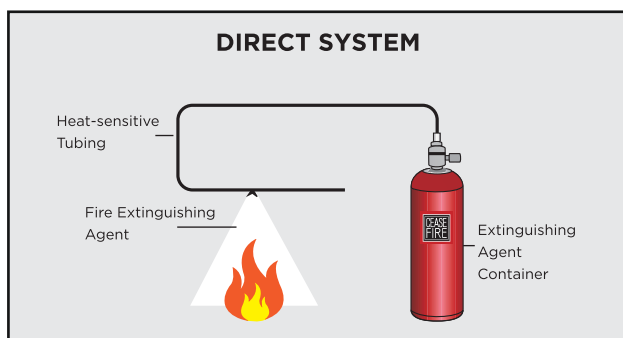

In the Direct system, heat-sensitive tubing also acts as an extinguishing agent delivery system. When a fire is detected, the tube bursts at that point, forming a miniature nozzle that sprays the extinguishing agent. Ideal for places where fires can break out in localized areas.

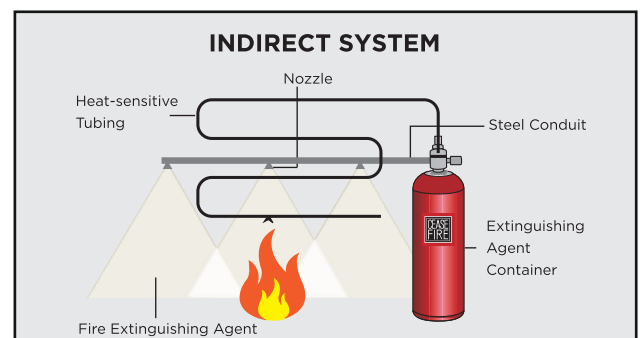

In the Indirect system, heat-sensitive tubing only acts as a detection device. In the event of a fire, the extinguishing agent is delivered through a steel pipe and sprayed across the entire area through strategically placed nozzles. Ideal for areas where fires can break at multiple points.

THE COMPLETE SYSTEM:

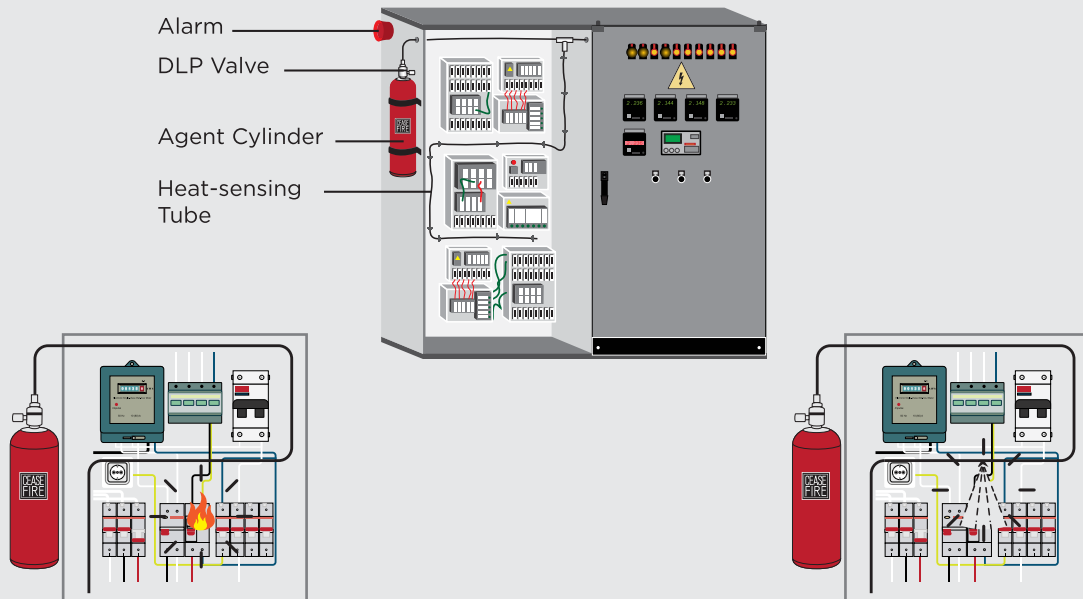

The single heat-sensitive polymer tube is connected to an extinguishing agent container via a pressure release valve. When a fire breaks out, it results in a drastic increase in temperature. When the temperature exceeds 150–180°C, the heat-sensitive tubing bursts, releasing the extinguishing agent via the direct or indirect line. The extinguishing agent is sprayed out of the container, flooding the micro-environment and instantly extinguishing the flame. Both are available in low and high-pressure variants.

The system is based on a wide array of extinguishing agents, making it compatible with a large kind of premises and effective against various fire hazards.

**LOW PRESSURE SYSTEMS**

<p>CQRS (MAP 90)</p> 	<p>CQRS (FLUROKETONE)</p> 	<p>CQRS (FLUORINE FREE FOAM)</p> 
--	--	--

**HIGH PRESSURE SYSTEMS**

CQRS  
(CO<sub>2</sub>)



## CQRS - ABC POWDER (MAP 90) - DIRECT

### PRODUCT OVERVIEW

Ceasefire Quick Response System has specially designed heat-sensitive pneumatic polymer tubing that acts as an extinguishing and detection device. When the flame comes into contact with the heat-sensitive tubing and reaches a temperature of 150–180 °C, the tubing bursts open at that exact spot and forms a nozzle which sprays the extinguishing agent out of the tube directly onto the flame, dousing the fire instantaneously.

This system uses MAP 90 as an extinguishing agent, which contains a 90% concentration of Mono Ammonium Phosphate. When sprayed on a burning surface, it absorbs the heat, melts, and fuses to form a thin, transparent layer that cuts off the oxygen to prevent re-ignition. Direct CQRS is available in two variations: engineered and pre-engineered.



### ENGINEERING DRAWINGS

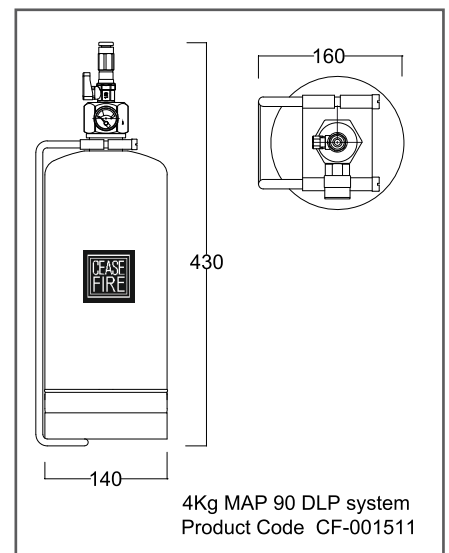
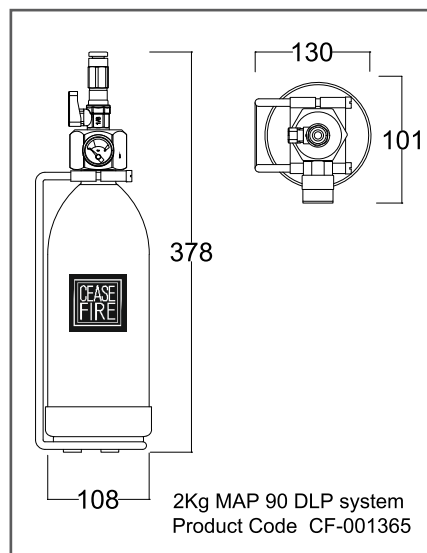
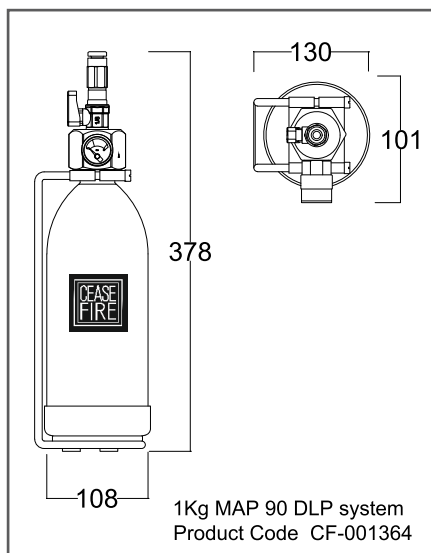



TECHNICAL SPECIFICATIONS

Product Code	UOM	CF-001364	CF-001365	CF-001511
Description	—	1Kg MAP 90 DLP system	2Kg MAP 90 DLP system	4Kg MAP 90 DLP system
Capacity of Agent	KG	1	2	4
Certification	—	PED UKCA-PED BSI TESTED	PED UKCA-PED BSI TESTED	PED UKCA-PED BSI TESTED
Dia of Shell	MM	108	108	140
Total Height (Appr.)	MM	378	378	430
MOC of Shell	—	M.S. Sheet (CRCA grade 2)	M.S. Sheet (CRCA grade 2)	M.S. Sheet (CRCA grade 2)
Mini. Wall Thickness	MM	1.2	1.6	1.6
Test Pressure	BAR	35	35	35
Anti Corrosive treatment	—	Outer surfaces are EP Powder coated having Thickness 50 Micron Min. RAL Shade 3000	Outer surfaces are EP Powder coated having Thickness 50 Micron Min. RAL Shade 3000	Outer surfaces are EP Powder coated having Thickness 50 Micron Min. RAL Shade 3000
Service Pressure	BAR	15	15	15
Type of Operating Mechanism	—	Automatic	Automatic	Automatic
Type of Pressure Gauge	—	Magnetic Bourdon Tube Type	Magnetic Bourdon Tube Type	Magnetic Bourdon Tube Type
Type of Dis. Fitting & Length	MM	NA	NA	NA
Type of valve	—	Direct Low Pressure Valve (DLP) with Single outlet	Direct Low Pressure Valve (DLP) with Single outlet	Direct Low Pressure Valve (DLP) with Single outlet
Length of Heat Sensing tube permitted	METER	10m long tube from each valve outlet to the end of single detection tube run at each outlet of DLP valve. Up to 4 branches of heat detection tube can be connected to a single container using tee connectors subject to the each branch length do not exceed 10m from the each valve outlet.		
Size of equipment/ enclosure can be protected by one system	M X M X M	L: 1 ; W: 0.5 ; H: 2	L: 2 ; W: 0.7 ; H: 2	L: 2.2 ; W: 0.85 ; H: 2

Product Code	UOM	CF-001364	CF-001365	CF-001511
Maximum number of compartment to be protected by one end of DLP valve.	—	There is no limitation on number of compartment to be protected however, the designer should follow the maximum tube length and volume limits as specified in points no. 5 & 6 above.		
Maximum tube activation height above hazard.	MM	Minimum 120mm to enclosure ceiling. Maximum 2000mm	Minimum 120mm to enclosure ceiling. Maximum 2000mm	Minimum 120mm to enclosure ceiling. Maximum 2000mm
Maximum free vent area of enclosure. (natural air flow)	Cm <sup>2</sup>	500	500	500
Maximum Air ventilation rate (forced air flow)	m <sup>3</sup> /sec	0.0416	0.0416	0.0416
Heat sensing tube pressure operation range.	°C	9-23 Bar @ 20°C	9-23 Bar @ 20°C	9-23 Bar @ 20°C
Operating Temperature Range	°C	-20°C to 60°C	-20°C to 60°C	-20°C to 60°C
Applicable to Type of Fire	—	A, B,C & Electrical Started Fire	A, B,C & Electrical Started Fire	A, B,C & Electrical Started Fire
Product Warranty	YEARS	1	1	1

## CERTIFICATIONS



## PRODUCT PICTURES



1 kg



2 kg



4 kg

# CQRS - ABC POWDER (MAP 90) - INDIRECT

## PRODUCT OVERVIEW

The revolutionary Ceasefire Quick Response Indirect System has a heat-sensing tube that bursts and releases the extinguishing agent through a separate discharge line from specially designed nozzles onto the fire, making it beneficial for micro-environments. Indirect CQRS uses MAP 90, which contains a 90% concentration of Mono Ammonium Phosphate. When sprayed on a burning surface, it absorbs the heat, melts, and fuses to form a thin, transparent layer, cutting off the oxygen to prevent re-ignition.

Backed by in-depth studies of common applications of the Ceasefire Quick Response System in the UK market, the Ceasefire Design Cell has created 15 pre-fabricated variants of the system, designed with the utmost precision to meet international quality standards.



## ENGINEERING DRAWINGS

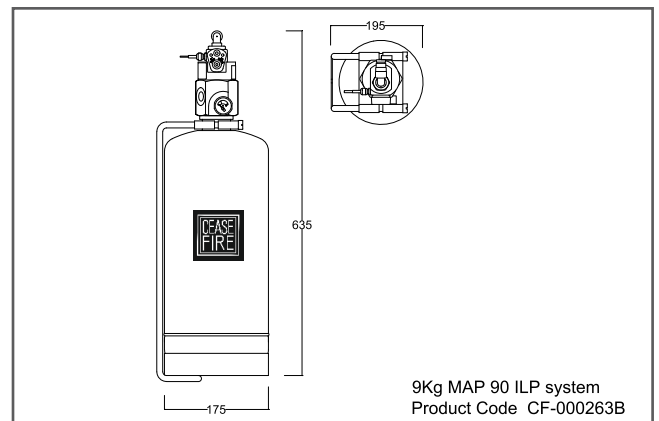
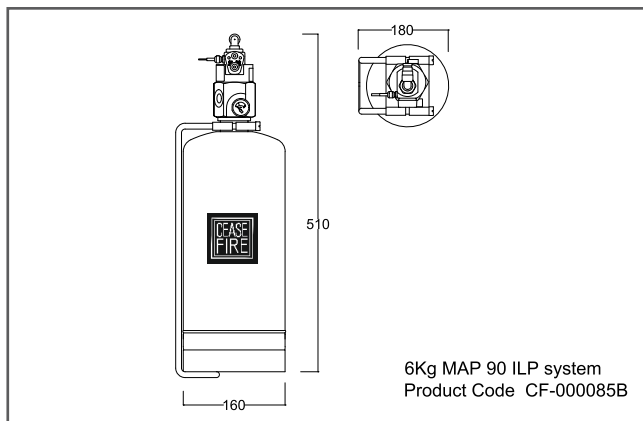
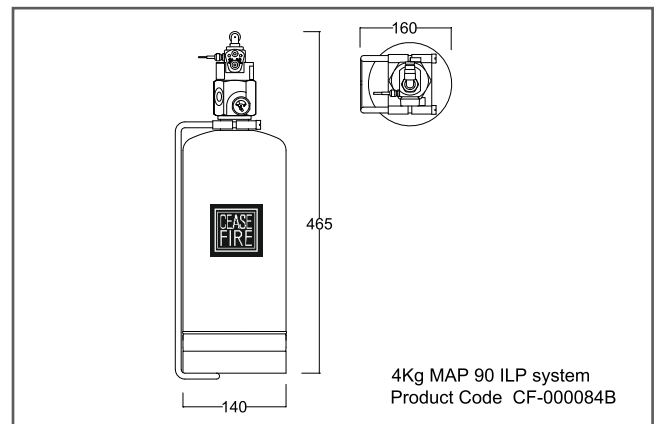
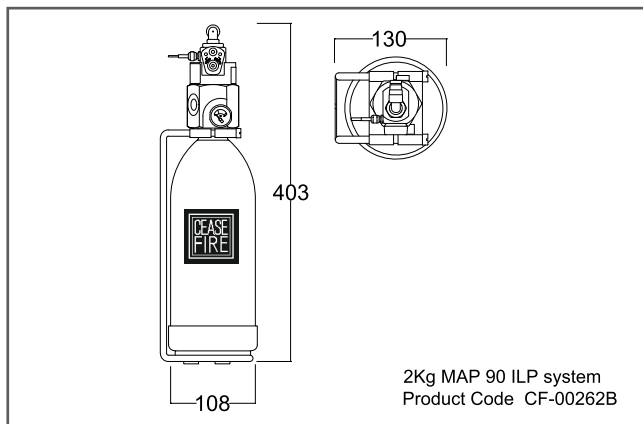



## TECHNICAL SPECIFICATIONS

Product Code	UOM	CF-000262B	CF-000084B	CF-000085B	CF-000263B
Description	—	2kg MAP90 ILP CQRS	4kg MAP90 ILP CQRS	6kg MAP90 ILP CQRS	9kg MAP90 ILP CQRS
Capacity of Agent	KG	2	4	6	9
Certification	—	PED UKCA-PED BSI TESTED	PED UKCA-PED BSI TESTED	PED UKCA-PED BSI TESTED	PED UKCA-PED BSI TESTED
Dia of Shell	MM	108	140	160	175
Total Height (Appr.)	MM	403	465	510	635
MOC of Shell	—	M.S. Sheet (CRCA grade 2)	M.S. Sheet (CRCA grade 2)	M.S. Sheet (CRCA grade 2)	M.S. Sheet (CRCA grade 2)
Mini. Wall Thickness	MM	1.6	1.6	1.6	1.6
Test Pressure	BAR	35	35	35	35
Anti Corrosive treatment	—	Outer surfaces are EP Powder coated having Thickness 50 Micron Min. RAL Shade 3000	Outer surfaces are EP Powder coated having Thickness 50 Micron Min. RAL Shade 3000	Outer surfaces are EP Powder coated having Thickness 50 Micron Min. RAL Shade 3000	Outer surfaces are EP Powder coated having Thickness 50 Micron Min. RAL Shade 3000
Service Pressure	BAR	15	15	15	15
Type of Operating Mechanism	—	Automatic/Manual	Automatic/Manual	Automatic/Manual	Automatic/Manual
Type of Pressure Gauge	—	Magnetic Bourdon Tube Type	Magnetic Bourdon Tube Type	Magnetic Bourdon Tube Type	Magnetic Bourdon Tube Type
Type of Dis. Fitting & Length	MM	Delivery pipe OD 10 mm x 1 mm Wall Thk. 4 M Besides Nozzle Network	Delivery pipe OD 10 mm x 1 mm Wall Thk. 6 M Besides Nozzle Network	Delivery pipe OD 10 mm x 1 mm Wall Thk. 8 M Besides Nozzle Network	Delivery pipe OD 10 mm x 1 mm Wall Thk. 12 M Besides Nozzle Network
No of Max. nozzles	—	2	4	6	8

Product Code	UOM	CF-000262B	CF-000084B	CF-000085B	CF-000263B
Type of valve	—	Indirect Low Pressure Valve (ILP) with two outlet	Indirect Low Pressure Valve (ILP) with two outlet	Indirect Low Pressure Valve (ILP) with two outlet	Indirect Low Pressure Valve (ILP) with two outlet
Operating Temperature Range	°C	5°C to 60°C	5°C to 60°C	5°C to 60°C	5°C to 60°C
Applicable to Type of Fire	—	A, B,C & Electrical Started Fire	A, B,C & Electrical Started Fire	A, B,C & Electrical Started Fire	A, B,C & Electrical Started Fire
Product Warranty	YEARS	1	1	1	1

## CERTIFICATIONS



## PRODUCT PICTURES



2 kg

4 kg

6 kg

9 kg

## CQRS - FLUOROKETONE (FK) - DIRECT

### PRODUCT OVERVIEW

Introducing Ceasefire's Quick Response System, which combines ground-breaking technology with functional simplicity. The most prominent feature of this system is the specially designed heat-sensitive pneumatic polymer tubing, which acts as an extinguishing and detection device. It is connected to a Ceasefire extinguishing agent container, while the rest of it runs unobtrusively throughout the area at risk. Direct CQRS is available in two variations: engineered and pre-engineered. The systems use fluoroketone, which does not leave any kind of residue. Because the extinguishing agent used is Clean Agent, this system is effective for combating any kind of fire.



### ENGINEERING DRAWINGS

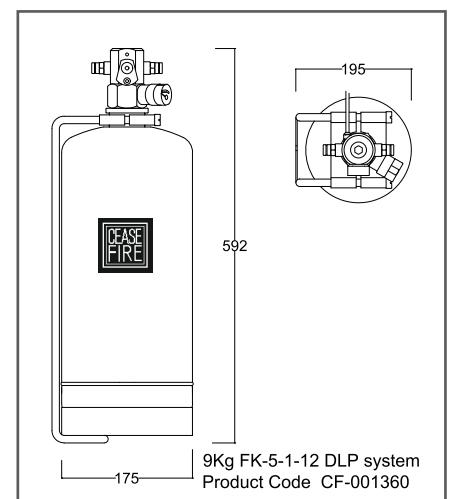
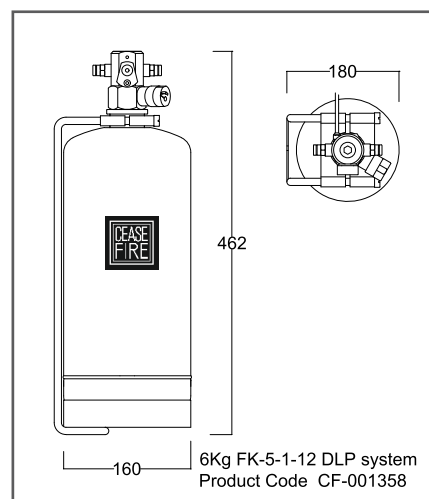
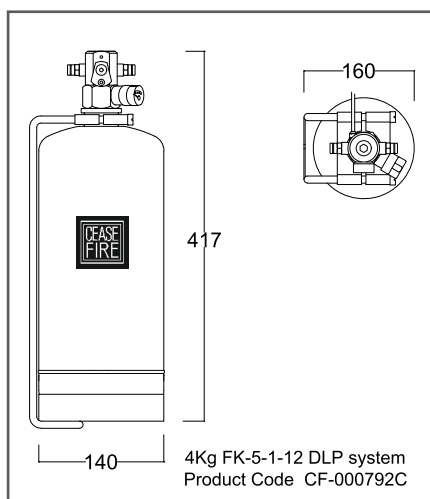
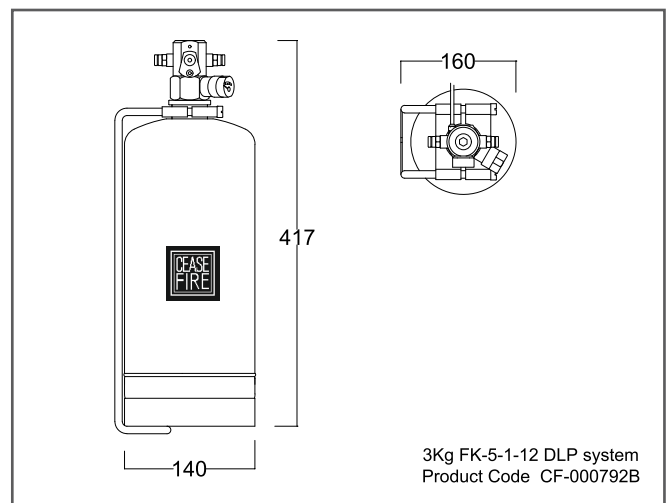
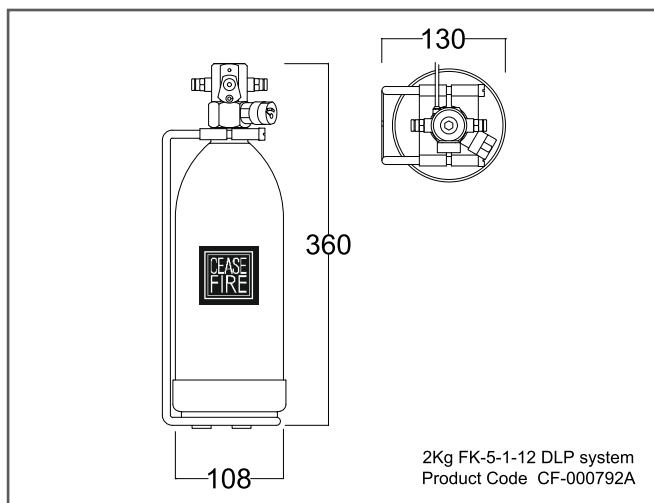



## TECHNICAL SPECIFICATIONS

Product Code	UOM	CF-00792A	CF-00792B	CF-00792C	CF-001358	CF-001360
Description	—	2Kg FK-5-1-12 DLP system	3Kg FK-5-1-12 DLP system	4Kg FK-5-1-12 DLP system	6Kg FK-5-1-12 DLP system	9Kg FK-5-1-12 DLP system
Capacity of Agent	KG	2	3	4	6	9
Certification	—	LPS 1666-LPCB PED UKCA-PED	LPS 1666-LPCB PED UKCA-PED	LPS 1666-LPCB PED UKCA-PED	PED UKCA-PED	PED UKCA-PED
Diameter of Shell	MM	108	140	140	160	175
Total Height (approx.)	MM	360	417	417	462	592
MOC of Shell	—	M.S. Sheet (CRCA grade 2)	M.S. Sheet (CRCA grade 2)	M.S. Sheet (CRCA grade 2)	M.S. Sheet (CRCA grade 2)	M.S. Sheet (CRCA grade 2)
Mini. Wall Thickness	MM	1.6	1.6	1.6	1.6	1.6
Test Pressure	BAR	35	35	35	35	35
Anti-Corrosive Treatment	—	Outer surfaces are EP Powder coated having Thickness 50 Micron Min. RAL Shade 3000	Outer surfaces are EP Powder coated having Thickness 50 Micron Min. RAL Shade 3000	Outer surfaces are EP Powder coated having Thickness 50 Micron Min. RAL Shade 3000	Outer surfaces are EP Powder coated having Thickness 50 Micron Min. RAL Shade 3000	Outer surfaces are EP Powder coated having Thickness 50 Micron Min. RAL Shade 3000
Service Pressure	BAR	15	15	15	15	15
Type of Operating Mechanism	—	Automatic	Automatic	Automatic	Automatic	Automatic
Type of Pressure Gauge	—	Magnetic Bourdon Tube Type	Magnetic Bourdon Tube Type	Magnetic Bourdon Tube Type	Magnetic Bourdon Tube Type	Magnetic Bourdon Tube Type



Product Code	UOM	CF-00792A	CF-00792B	CF-00792C	CF-001358	CF-001360
Type of Dis. Fitting & Length	MM	NA	NA	NA	NA	NA
Type of valve	—	Direct Low Pressure Valve (DLP) with two outlet	Direct Low Pressure Valve (DLP) with two outlet	Direct Low Pressure Valve (DLP) with two outlet	Direct Low Pressure Valve (DLP) with two outlet	Direct Low Pressure Valve (DLP) with two outlet
Length of Heat Sensing tube	METER	10m long tube from each valve outlet to the end of single detection tube run at each outlet of DLP valve. Up to 4 branches of heat detection tube can be connected to a single container using tee connectors subject to each branch length do not exceed 10m from each valve outlet.			10m long tube from each valve outlet to the end of single detection tube run at each outlet of DLP valve. Up to 4 branches of heat detection tube can be connected to a single container using tee connectors subject to each branch length do not exceed 12m from each valve outlet.	
Size of equipment /enclosure can be protected by one system	—	The volume of largest enclosure within the panel to be protected shall not exceed 2 cubic meters.			The volume of largest enclosure within the panel to be protected shall not exceed 3 cubic meters.	
Maximum number of compartments to be protected by one end of DLP valve.	—	There is no limitation on number of compartments to be protected however, the designer should follow the maximum tube length and volume limits as specified in points no. 5 & 6 above.				
Maximum distance of the detector tube from potential secondary fire sources	MM	200mm (for cabinets with ventilations), 600mm (for cabinets without ventilation)				
Maximum free vent area of enclosure. (natural air flow)	Cm <sup>2</sup>	At High level - 500 At low level - 157	At High level - 500 At low level - 250	At High level - 500 At low level - 500	At High level - 500 At low level - 500	At High level - 500 At low level - 500
Maximum free vent area of enclosure. (forced air flow, high, outward)	Cm <sup>2</sup>	At High level - 500 At low level - 250	At High level - 500 At low level - 500	At High level - 500 At low level - 500	At High level - 600 At low level - 600	At High level - 600 At low level - 600
Maximum Air ventilation rate (forced air flow, high level, outward)	m <sup>3</sup> /sec	0.025 to 0.035	0.05 to 0.07	0.05 to 0.07	0.05 to 0.07	0.05 to 0.07
Maximum free vent area of enclosure. (forced air flow, Low level, inward)	Cm <sup>2</sup>	At High level - 250 At low level - 250	At top - 500 At Bottom - 250	At top - 500 At Bottom - 250	At top - 600 At Bottom - 300	At top - 600 At Bottom - 300
Maximum Air ventilation rate (forced air flow, low level, inward)	m <sup>3</sup> /sec	0.02 to 0.25	0.025 to 0.035	0.025 to 0.035	0.025 to 0.035	0.025 to 0.035
Heat sensing tube pressure operation range.	°C	9-23 Bar @ 20°C	9-23 Bar @ 20°C	9-23 Bar @ 20°C	9-23 Bar @ 20°C	9-23 Bar @ 20°C

Product Code	UOM	CF-00792A	CF-00792B	CF-00792C	CF-001358	CF-001360
Operating Temperature Range	°C	-20°C to 60°C	-20°C to 60°C	-20°C to 60°C	-20°C to 60°C	-20°C to 60°C
Applicable to Type of Fire	—	A, B, & Electrical Started Fire	A, B, & Electrical Started Fire	A, B, & Electrical Started Fire	A, B, & Electrical Started Fire	A, B, & Electrical Started Fire
Product Warranty	YEARS	1	1	1	1	1

\* It includes Empty Extinguisher, Contents and Plastic Base only (where applicable) - not including hose, Wall bracket or Packaging.

\*\* Includes all packaging, hose / horn and bracket

## CERTIFICATIONS



## PRODUCT PICTURES



## CQRS - FLUOROKETONE (FK) - INDIRECT

### PRODUCT OVERVIEW

In the indirect version of this system, this tube detects the fire and bursts, allowing the pressure inside to drop, signaling the valve to release the extinguishing agent through a separate discharge line. Indirect CQRS makes use of fluoroketone, which happens to be a cold gas, therefore, extinguishes fire by absorbing heat from it. After being sprayed, it leaves behind no residue and works on class A, B, C, and Electrically started fires.



### ENGINEERING DRAWINGS

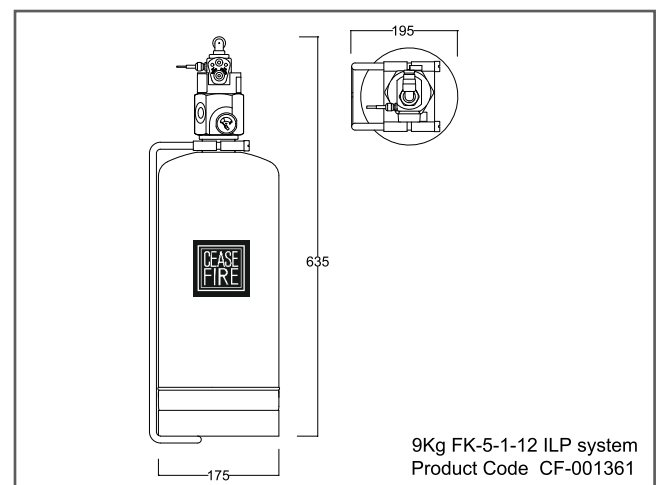
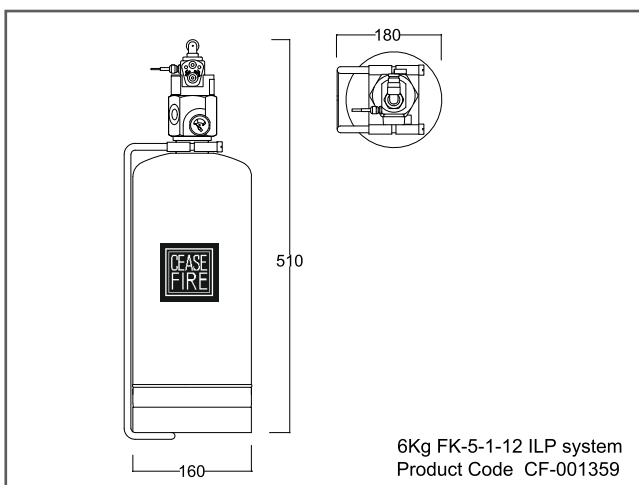
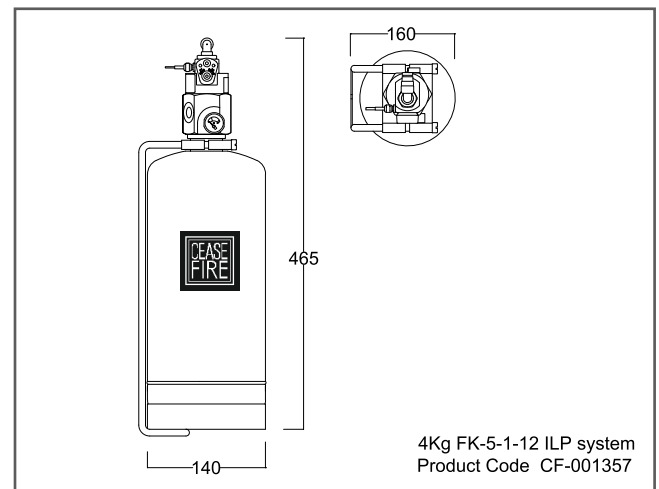
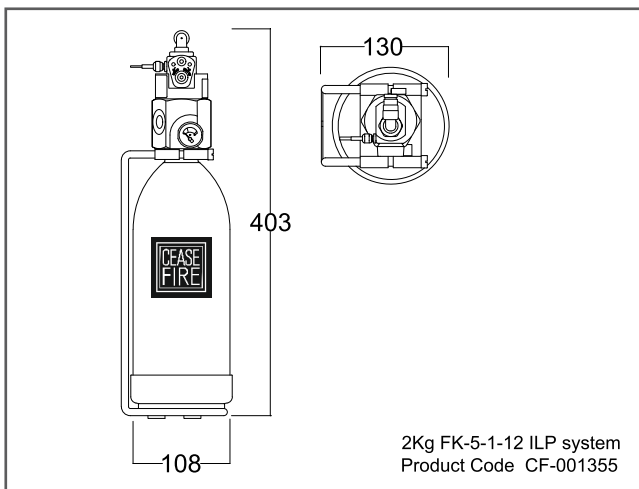



## TECHNICAL SPECIFICATIONS

Product Code	UOM	CF-001355	CF-001357	CF-001359	CF-0013561
Description	—	2kg- FK 5-1-12 clean agent with (ILP) with integrated ball valve.	4kg- FK 5-1-12 clean agent with (ILP) with integrated ball valve .	6kg- FK 5-1-12 clean agent with (ILP) with integrated ball valve.	9kg- FK 5-1-12 clean agent with (ILP) with integrated ball valve.
Capacity of Agent	KG	2 (-5%)	4 (-5%)	6 (-5%)	9 (-5%)
Certification	—	PED UKCA-PED BSI TESTED	PED UKCA-PED BSI TESTED	PED UKCA-PED BSI TESTED	PED UKCA-PED BSI TESTED
Diameter of Shell	MM	108	140	160	175
Total Height (approx.)	MM	403	465	510	635
MOC of Shell	—	M.S. Sheet (CRCA )	M.S. Sheet (CRCA )	M.S. Sheet (CRCA )	M.S. Sheet (CRCA )
Mini. Wall Thickness	MM	1.6	1.6	1.6	1.6
Test Pressure	BAR	35	35	35	35
Anti-Corrosive Treatment	—	Outer surfaces are EP Powder coated having Dry Film Thickness 50 Micron (Min.) RAL Shade 3000	Outer surfaces are EP Powder coated having Dry Film Thickness 50 Micron (Min.) RAL Shade 3000	Outer surfaces are EP Powder coated having Dry Film Thickness 50 Micron (Min.) RAL Shade 3000	Outer surfaces are EP Powder coated having Dry Film Thickness 50 Micron (Min.) RAL Shade 3000
Service Pressure	BAR	15	15	15	15
Type of Operating Mechanism	—	Automatic / Manual	Automatic / Manual	Automatic / Manual	Automatic / Manual
Type of Pressure Gauge	—	Magnetic Bourdon Tube Type	Magnetic Bourdon Tube Type	Magnetic Bourdon Tube Type	Magnetic Bourdon Tube Type
Type of Dis. pipe & Length	MM	Delivery pipe OD 10MM x 1MM Wall Thk. 5M	Delivery pipe OD 10MM x 1MM Wall Thk. 8 M	Delivery pipe OD 10MM x 1MM Wall Thk. 10M (Stright Line) 15 M (Ring Form)	Delivery pipe OD 10MM x 1MM Wall Thk. 12 M (Stright Line) 20 M (Ring Form)
No of Max. nozzles	—	2	4	6	8
Type of valve	—	Indirect Low Pressure Valve (ILP) with Single outlet	Indirect Low Pressure Valve (ILP) with Single outlet	Indirect Low Pressure Valve (ILP) with Single outlet	Indirect Low Pressure Valve (ILP) with Single outlet



Product Code	UOM	CF-001355	CF-001357	CF-001359	CF-0013561
Operating Temperature Range	°C	-20°C to 60°C	-20°C to 60°C	-20°C to 60°C	-20°C to 60°C
Applicable to Type of Fire	—	A, B, & Electrical Started Fire	A, B, & Electrical Started Fire	A, B, & Electrical Started Fire	A, B, & Electrical Started Fire
Product Warranty	YEAR	1	1	1	1

### CERTIFICATIONS



### PRODUCT PICTURES



2 kg

4 kg

6 kg

9 kg

## CQRS - FOAM - DIRECT

### PRODUCT OVERVIEW

In the Direct system, the heat-sensitive tubing also acts as an extinguishing agent delivery system. When a fire is detected, the tube bursts at that point, forming a miniature nozzle that sprays the extinguishing agent. It is ideal for places where fires can break out in localized areas. This system makes use of foam, which covers the entire surface area and cuts off the oxygen supply, thereby smothering the fire and extinguishing the flames.



### ENGINEERING DRAWINGS

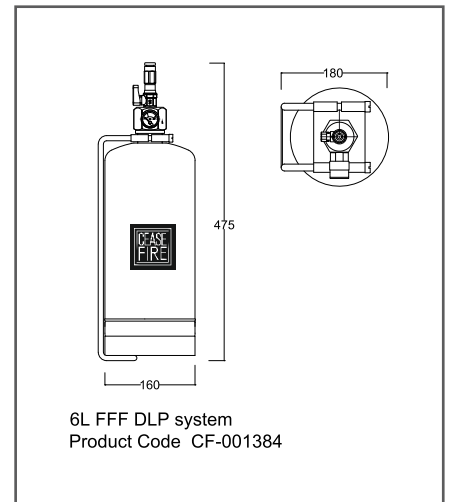
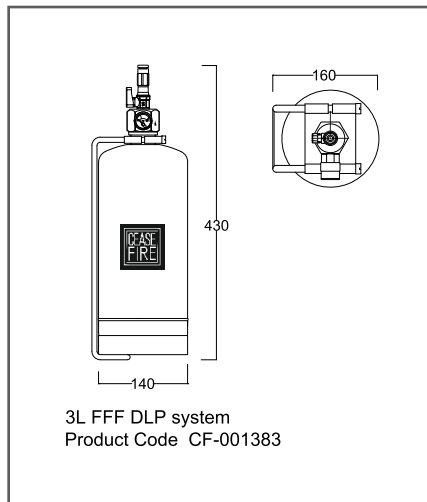
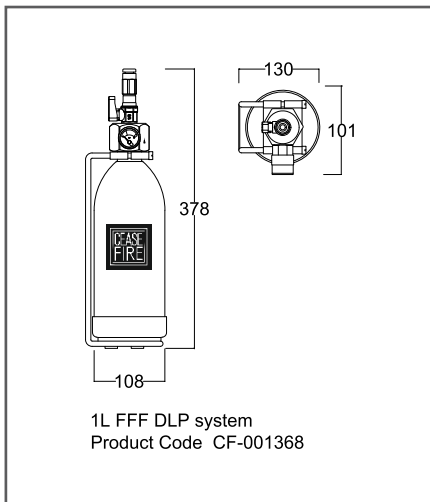

### TECHNICAL SPECIFICATIONS

Product Code	UOM	CF-001368	CF-001383	CF-001384
<b>Description</b>	—	1L FFF DLP system	3L FFF DLP system	6L FFF DLP system
<b>Capacity of Agent</b>	L	1	3	6
<b>Certification</b>	—	PED UKCA-PED BSI TESTED	PED UKCA-PED BSI TESTED	PED UKCA-PED BSI TESTED
<b>Dia of Shell</b>	MM	108	140	160



Product Code	UOM	CF-001368	CF-001383	CF-001384
Total Height (Appr.)	MM	378	430	475
MOC of Shell	—	SS 316L (1.4435)	M.S. Sheet (CRCA grade 2)	M.S. Sheet (CRCA grade 2)
Mini. Wall Thickness	MM	1.2	1.6	1.6
Test Pressure	BAR	35	35	35
Anti Corrosive treatment	—	Outer surfaces are EP Powder coated having Thickness 50 Micron Min. RAL Shade 3000	Outer surfaces are EP Powder coated having Thickness 50 Micron Min. RAL Shade 3000	Outer surfaces are EP Powder coated having Thickness 50 Micron Min. RAL Shade 3000
Service Pressure	BAR	15	15	15
Type of Operating Mechanism	—	Automatic	Automatic	Automatic
Type of Pressure Gauge	—	Magnetic Bourdon Tube Type	Magnetic Bourdon Tube Type	Magnetic Bourdon Tube Type
Type of Dis. Fitting & Length	MM	NA	NA	NA
Type of valve	—	Direct Low Pressure Valve (DLP) with twin outlet	Direct Low Pressure Valve (DLP) with twin outlet	Direct Low Pressure Valve (DLP) with twin outlet
Length of Heat Sensing tube permitted	METER	10m long tube from each valve outlet to the end of single detection tube run at each outlet of DLP valve. Up to 4 branches of heat detection tube can be connected to a single container using tee connectors subject to the each branch length do not exceed 10m from the each valve outlet.		
Size of equipment/ enclosure can be protected by one system	M X M X M	L: 0.67m; W: 0.5m; H: 0.7m Max coverage area : 0.335 sq. m	L: 1m; W: 0.7m; H : 0.85m Max. coverage area : 0.7 sq m	L: 1.2m; W: 0.85m; H: 0.9m Max coverage area : 1.02 sq m
Maximum number of compartment to be protected by one end of DLP valve.	—	There is no limitation on number of compartment to be protected however, the designer should follow the maximum tube length and volume limits as specified in points no. 5 & 6 above.		
Maximum tube activation height above hazard.	MM	Minimum 120mm to enclosure ceiling. Maximum 2000mm	Minimum 120mm to enclosure ceiling. Maximum 2000mm	Minimum 120mm to enclosure ceiling. Maximum 2000mm
Heat sensing tube pressure operation range.	°C	9-23 Bar @ 20°C	9-23 Bar @ 20°C	9-23 Bar @ 20°C
Operating Temperature Range	°C	15	15	15

Product Code	UOM	CF-001368	CF-001383	CF-001384
Applicable to Type of Fire	—	A, B Class Fire	A, B Class Fire	A, B Class Fire
Product Warranty	YEAR	1	1	1

## CERTIFICATIONS



## PRODUCT PICTURES



1 ltr



3 ltr



6 ltr

# CQRS - FOAM - INDIRECT

## PRODUCT OVERVIEW

The system supports instant and automatic activation, eliminating the need for human intervention. It is in a perpetual state of readiness to combat a fire as soon as it breaks out. Flexible tubing allows protection in areas that are difficult to access and may not be able to accommodate any other means of detection. This system uses foam as an extinguishing agent, which covers the entire surface area and cuts off the oxygen supply, thereby smothering the fire and extinguishing the flames.



## ENGINEERING DRAWINGS

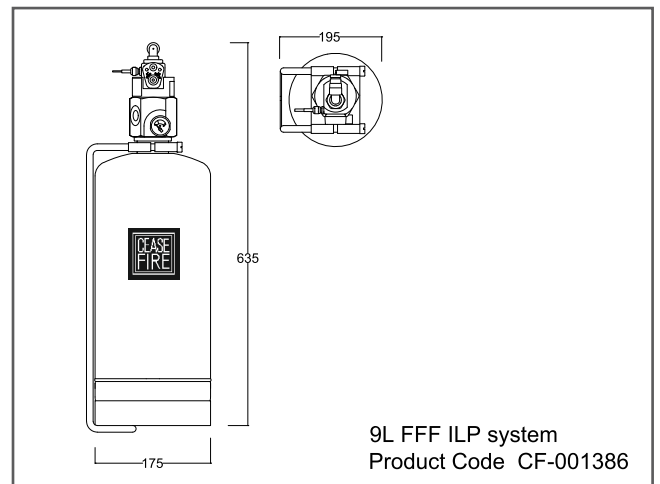
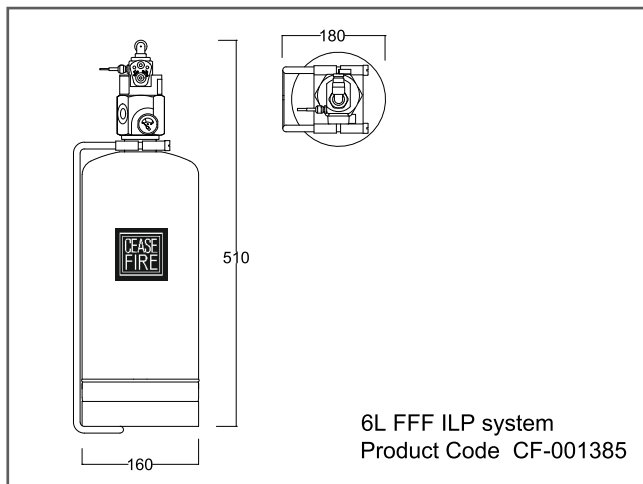
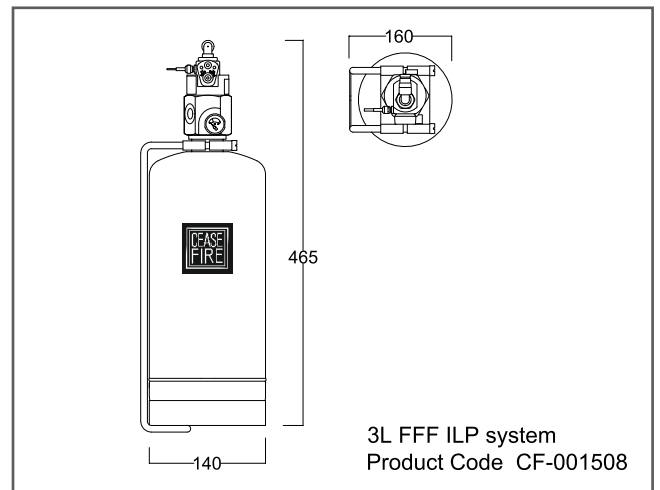
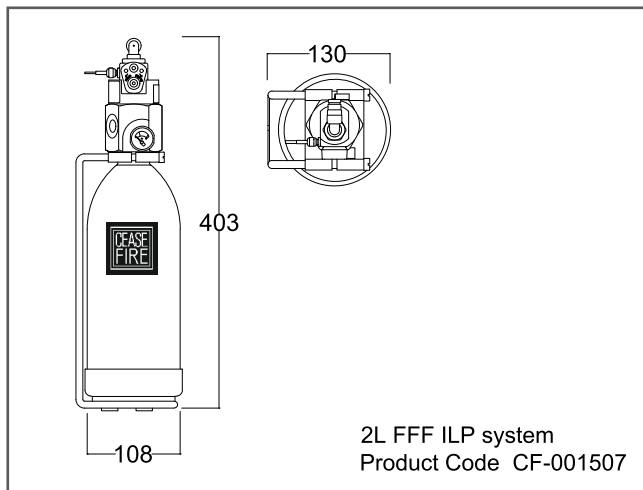

**TECHNICAL SPECIFICATIONS**

Product Code	UOM	CF-001507	CF-001508	CF-001385	CF-001386
<b>Description</b>	—	2L FFF ILP system	3L FFF ILP system	6L FFF ILP system	9L FFF ILP system
<b>Capacity of Agent</b>	<b>L</b>	2	3	6	9
<b>Certification</b>	—	PED UKCA-PED BSI TESTED	PED UKCA-PED BSI TESTED	PED UKCA-PED BSI TESTED	PED UKCA-PED BSI TESTED
<b>Dia of Shell</b>	<b>MM</b>	108	140	160	175
<b>Total Height (Appr.)</b>	<b>MM</b>	403	465	510	635
<b>MOC of Shell</b>	—	M.S. Sheet (CRCA grade 2)	M.S. Sheet (CRCA grade 2)	M.S. Sheet (CRCA grade 2)	M.S. Sheet (CRCA grade 2)
<b>Mini. Wall Thickness</b>	<b>MM</b>	1.6	1.6	1.6	2.0
<b>Test Pressure</b>	<b>BAR</b>	35	35	35	35
<b>Anti Corrosive treatment</b>	—	Outer surfaces are EP Powder coated having Thickness 50 Micron Min. RAL Shade 3000	Outer surfaces are EP Powder coated having Thickness 50 Micron Min. RAL Shade 3000	Outer surfaces are EP Powder coated having Thickness 50 Micron Min. RAL Shade 3000	Outer surfaces are EP Powder coated having Thickness 50 Micron Min. RAL Shade 3000
<b>Service Pressure</b>	<b>BAR</b>	15	15	15	15
<b>Type of Operating Mechanism</b>	—	Automatic/Manual	Automatic/Manual	Automatic/Manual	Automatic/Manual
<b>Type of Pressure Gauge</b>	—	Magnetic Bourdon Tube Type	Magnetic Bourdon Tube Type	Magnetic Bourdon Tube Type	Magnetic Bourdon Tube Type
<b>Type of Dis. Fitting &amp; Length</b>	<b>MM</b>	Delivery pipe OD 10MM x 1MM Wall Thk. 4 M Besides Nozzle Network	Delivery pipe OD 10MM x 1MM Wall Thk. 6 M Besides Nozzle Network	Delivery pipe OD 10MM x 1MM Wall Thk. 8 M Besides Nozzle Network	Delivery pipe OD 10MM x 1MM Wall Thk. 12 M Besides Nozzle Network

Product Code	UOM	CF-001507	CF-001508	CF-001385	CF-001386
No of Max. nozzles	—	2	4	6	8
Type of valve	—	Indirect Low Pressure Valve (ILP) with two outlet	Indirect Low Pressure Valve (ILP) with two outlet	Indirect Low Pressure Valve (ILP) with two outlet	Indirect Low Pressure Valve (ILP) with two outlet
Operating Temperature Range	°C	5°C to 60°C	5°C to 60°C	5°C to 60°C	5°C to 60°C
Applicable to Type of Fire	—	A, B Class Fire	A, B Class Fire	A, B Class Fire	A, B Class Fire
Product Warranty	YEAR	1	1	1	1

## CERTIFICATIONS



## PRODUCT PICTURES



2 L



3 L



6 L



9 L

# CQRS - CO2 - DIRECT

## PRODUCT OVERVIEW

The Ceasefire Direct Quick Response System is ideal for situations in which fires can break out in localized areas. The Direct System is designed by the Ceasefire Design Cell and installed by Ceasefire's expert team after an assessment of the location. It uses carbon dioxide as an extinguishing agent, also known as "dry ice." Due to its non-corrosive nature, it doesn't leave behind any residue after being sprayed to extinguish fires. At the same time, it causes no harm to the environment.



## ENGINEERING DRAWINGS

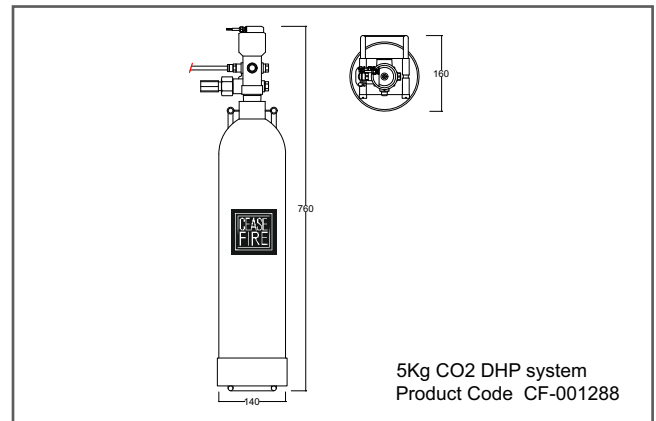
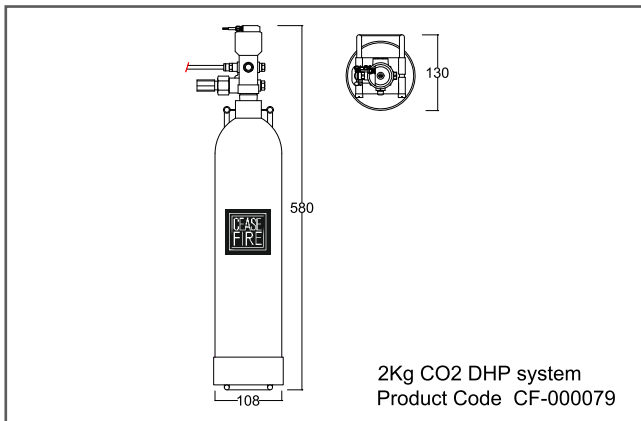

## TECHNICAL SPECIFICATIONS

Product Code	UOM	CF-000079	CF-001288
Description	—	2Kg, CO2 DHP system	5Kg, CO2 DHP system
Capacity of Agent	KG	2	5
Certification	—	PED UKCA-PED BSI TESTED	PED UKCA-PED BSI TESTED
Dia of Shell	MM	108	140



Product Code	UOM	CF-000079	CF-001288
Total Height (Appr.)	MM	580	760
MOC of Shell	—	Carbon Steel (37Mn/ 34CrMo4 )	Carbon Steel (37Mn/ 34CrMo4 )
Mini. Wall Thickness	MM	2.6	2.6
Test Pressure	BAR	250	250
Anti Corrosive treatment	—	Outer surfaces are EP Powder coated having Thickness 50 Micron Min. RAL Shade 3000	Outer surfaces are EP Powder coated having Thickness 50 Micron Min. RAL Shade 3000
Service Pressure	BAR	17-23	17-23
Type of Operating Mechanism	—	Automatic	Automatic
Tube length and Branch limitations.	METER	15m long tube from valve outlet to the end of single detection tube run. Up to 4 branches of heat detection tube can be connected to a single container using tee connectors subject to each branch length do not exceed 15m from valve outlet.	
Heat sensing tube pressure operation range.	°C	17-23 Bar @ 20°C	17-23 Bar @ 20°C
Size of equipment/ enclosure can be protected by one system	—	The volume of largest enclosure within the panel to be protected shall not exceed 1 cubic meter.	The volume of largest enclosure within the panel to be protected shall not exceed 2 cubic meters.
Maximum number of compartments to be protected by one end of DHP valve.	METER	There is no limitation on number of compartments to be protected however, the designer should follow the maximum tube length and volume limits as specified in points no. 6 above.	There is no limitation on number of compartments to be protected however, the designer should follow the maximum tube length and volume limits as specified in points no. 6 above.
Operating temperature	°C	-20°C to 60°C	-20°C to 60°C
Agent container pressure	BAR	70 bar approx.	70 bar approx.
Filling Ratio (max)	KG/L	0.667	0.667
Maximum permissible weight loss (Kg)	—	5% of gross mass	5% of gross mass
Hazard Consideration	—	Dry electrical hazard (NFPA 12)	Dry electrical hazard (NFPA 12)

Product Code	UOM	CF-000079	CF-001288
Required Extinguishing agent flooding factor as per NFPA 12	KG/m <sup>3</sup>	1.6	1.6
Maximum tube activation height above hazard/protected risk.	MM	120	120
Maximum distance of the detector tube from potential secondary fire sources	MM	200mm (for cabinets with ventilations) 600mm (for cabinets without ventilation)	200mm (for cabinets with ventilations) 600mm (for cabinets without ventilation)
Maximum free vent area of enclosure. (natural air flow)	CM <sup>2</sup>	At High level - 500 At low level - 500	At High level - 500 At low level - 500
Maximum free vent area of enclosure. (forced air flow, high, outward)	CM <sup>2</sup>	At High level - 500 At low level - 500	At High level - 500 At low level - 500
Maximum Air ventilation rate (forced air flow, high level, outward)	M <sup>3</sup> /SEC	0.075 to 0.10	0.075 to 0.10
Applicable to Type of Fire	—	B, C ,& Electrical Started Fire	B, C ,& Electrical Started Fire
Product Warranty	YEAR	1	1

## CERTIFICATIONS



## PRODUCT PICTURES



2 KG



5 KG

## CQRS - CO2 - INDIRECT

### PRODUCT OVERVIEW

The Ceasefire Indirect Quick Response System is ideal for locations where there is a chance of the ignition of fires at multiple points. For example, in a large server, where a voltage surge can short-circuit components at multiple locations and cause them to catch fire. It uses carbon dioxide as an extinguishing agent, also known as "dry ice." Due to its non-corrosive nature, it doesn't leave behind any residue after being sprayed to extinguish fires. At the same time, it causes no harm to the environment.



### ENGINEERING DRAWINGS

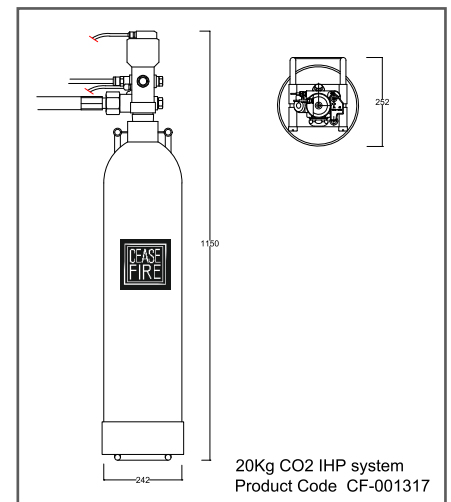
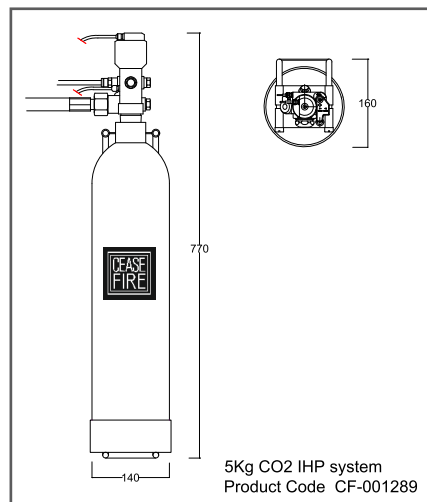
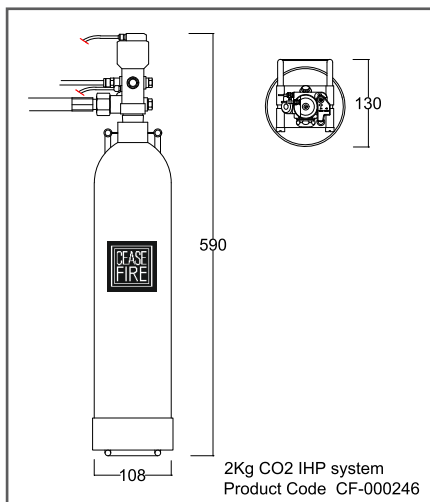

### TECHNICAL SPECIFICATIONS

Product Code	UOM	CF-000246	CF-001289	CF-001317
Description	—	2Kg, CO <sub>2</sub> IHP system	5Kg, CO <sub>2</sub> IHP system	20Kg, CO <sub>2</sub> IHP system
Capacity of Agent	KG	2	5	20
Certification	—	PED UKCA-PED BSI TESTED	PED UKCA-PED BSI TESTED	PED UKCA-PED BSI TESTED



Product Code	UOM	CF-000246	CF-001289	CF-001317
Dia of Shell	MM	108	140	232
Total Height (Appr.)	MM	590	770	1150
MOC of Shell	—	Carbon Steel (37Mn/ 34CrMo4 )	Carbon Steel (37Mn/ 34CrMo4 )	Carbon Steel (37Mn/ 34CrMo4 )
Mini. Wall Thickness	MM	2.0	2.5	3.5
Test Pressure	BAR	250	250	250
Anti Corrosive treatment	—	Outer surfaces are EP Powder coated having Thickness 50 Micron Min. RAL Shade 3000	Outer surfaces are EP Powder coated having Thickness 50 Micron Min. RAL Shade 3000	Outer surfaces are EP Powder coated having Thickness 50 Micron Min. RAL Shade 3000
Service Pressure	BAR	17-23	17-23	17-23
Type of Operating Mechanism	—	Automatic/Manual	Automatic/Manual	Automatic/Manual
Type of Pressure Gauge	—	Magnetic Bourdon Tube Type	Magnetic Bourdon Tube Type	Magnetic Bourdon Tube Type
Type of Dis. Fitting & Length	MM	Delivery pipe OD 10MM x 1MM Wall Thk. 4 M Besides Nozzle Network	Delivery pipe OD 10MM x 1MM Wall Thk. 6 M Besides Nozzle Network	Delivery pipe OD 10MM x 1MM Wall Thk. 20 M Besides Nozzle Network
No of Max. nozzles	—	4	6	20
Type of valve	—	Direct High-Pressure Valve (IHP) with single outlet	Direct High-Pressure Valve (IHP) with single outlet	Direct High-Pressure Valve (IHP) with single outlet
Operating Temperature Range	°C	-20°C to 60°C	-20°C to 60°C	-20°C to 60°C

Product Code	UOM	CF-000246	CF-001289	CF-001317
Applicable to Type of Fire	—	B, C ,& Electrical Started Fire	B, C ,& Electrical Started Fire	B, C ,& Electrical Started Fire
Product Warranty	YEARS	1	1	1

## CERTIFICATIONS



## PRODUCT PICTURES



\*v2' Published Date is 27-04-2026.

\*\*Regular R&D and product improvisations may lead to change in product specifications in this data sheet, without any prior notice.