

WATER MIST BASED PORTABLE EXTINGUISHERS

PRODUCT OVERVIEW

The revolutionary new Watermist Extinguishers are designed to combat Class A, F, and electrically started fires. Specially designed rotors in the extinguisher mixes water and air in a pre-set proportion to generate a fine mist of 40–60-micron molecules. These tiny droplets have a surface area coverage many times higher than water. The mist is then propelled through a specially designed nozzle, giving it a large throw.

On coming into contact with the flames, it turns into steam and envelops the flames. The water cools the fire below combustion levels and cuts off the oxygen supply. Without oxygen or heat, the fire dies out in seconds. This isn't water in its natural state, the dangers of electrocution and flooding are eliminated. This means the powerful, reliable, and efficient extinguisher can be used on most kinds of fires, including electrically started fires.



ENGINEERING DRAWINGS

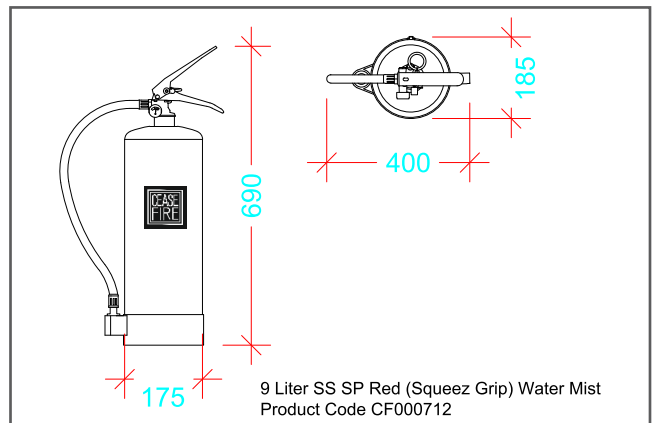
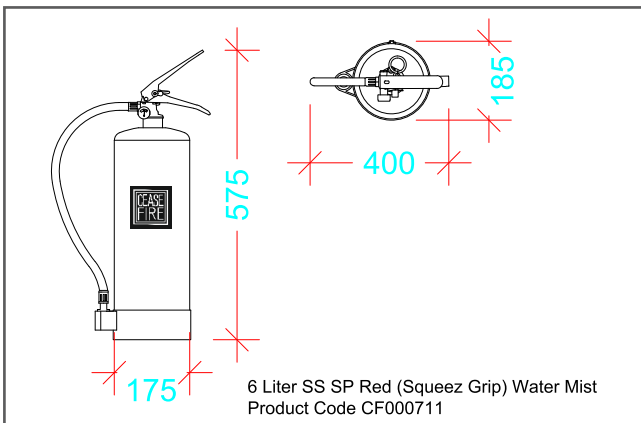
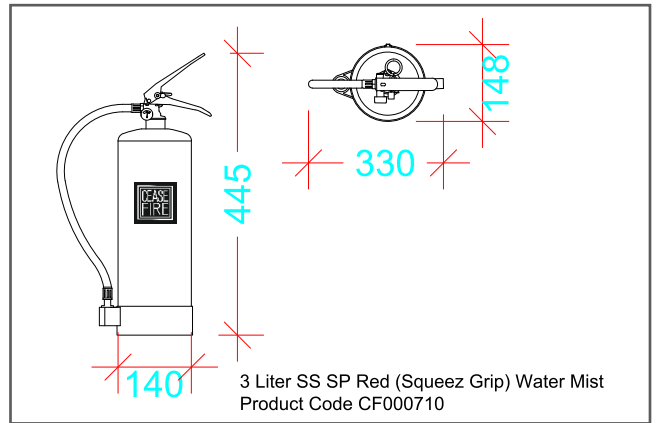
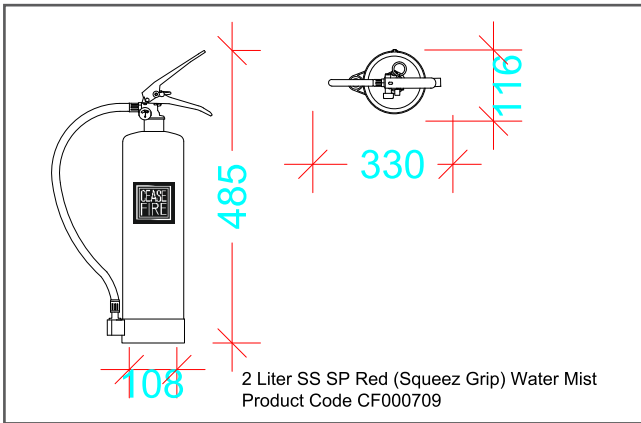



TECHNICAL SPECIFICATIONS

Product Code	UOM	CF-000709	CF-000710	CF-000711	CF-000712
Description	—	Fire Ext Water Mist 2L SS SP Red	Fire Ext Water Mist 3L SS SP Red	Fire Ext Water Mist 6L SS SP Red	Fire Ext Water Mist 9L SS SP Red
Capacity of Agent	L	2-5%	3-5%	6-5%	9-5%
Certification	—	BS EN3-LPCB BS EN3-KITEMARK PED UKCA-PED	BS EN3 - LPCB BS EN3 - KITEMARK EU-MED UKCA-MER PED UKCA-PED	BS EN3 - LPCB BS EN3 - KITEMARK EU-MED UKCA-MER PED UKCA-PED	BS EN3 - LPCB BS EN3 - KITEMARK EU-MED UKCA-MER PED UKCA-PED
Diameter of Shell	MM	108	140	175	175
Total Height (approx.)	MM	485	445	575	690
MOC of Shell	—	SS 304 (1.4301)	SS 304 (1.4301)	SS 304 (1.4301)	SS 304 (1.4301)
Mini. Wall Thickness	MM	1.5	1.5	1.39	1.49
Test Pressure	BAR	35	35	35	35
Anti-Corrosive Treatment	—	Outer surfaces were EP Powder coated having Thickness 50 Micron Min. RAL Shade 3000	Outer surfaces were EP Powder coated having Thickness 50 Micron Min. RAL Shade 3000	Outer surfaces were EP Powder coated having Thickness 50 Micron Min. RAL Shade 3000	Outer surfaces were EP Powder coated having Thickness 50 Micron Min. RAL Shade 3000
Service Pressure	BAR	15	15	15	15
Type of Operating Mechanism	—	Squeeze Grip with NRV and Burst Disc.	Squeeze Grip with NRV and Burst Disc.	Squeeze Grip with NRV and Burst Disc.	Squeeze Grip with NRV and Burst Disc.
Type of Pressure Gauge	—	Magnetic Bourdon Tube Type	Magnetic Bourdon Tube Type	Magnetic Bourdon Tube Type	Magnetic Bourdon Tube Type



Product Code	UOM	CF-000709	CF-000710	CF-000711	CF-000712
Type of Dis. Fitting & Length	MM	EPDM Rubber Braided Hose Pipe with nozzle Length of Hose 300 mm (Min.)	EPDM Rubber Braided Hose Pipe with nozzle Length of Hose 300 mm (Min.)	EPDM Rubber Braided Hose Pipe with nozzle Length of Hose 500 mm (Min.)	EPDM Rubber Braided Hose Pipe with nozzle Length of Hose 600 mm (Min.)
Throw up to (approx.)	METER	3	3	3	3
Average Discharge Duration as per BS EN 3-7:2004+A1:2007, clause 71.2	SEC.	6	9	9	9
Fire Rating	—	5A 25F	8A 25F	13A 75F	21A 75F
Operating Temperature Range	°C	From +5°C to +60°C	From +5°C to +60°C	From +5°C to +60°C	From +5°C to +60°C
Applicable to Type of Fire	—	A, F & Electrical Started Fire	A, F & Electrical Started Fire	A, F & Electrical Started Fire	A, F & Electrical Started Fire
Filled Weight Range*	KG	Approx. 4.50	Approx 5.90	Approx 10.60	Approx 14.60
Packed Weight Range (approx)**	KG	4.95	6.35	11.2	15
Packed Size Length x Width x Height	MM	125 x 125 x 520	160 x 160 x 470	190 x 195 x 610	190 x 195 x 735
Product Warranty	YEAR	10	10	10	10

*It includes Empty Extinguisher, Contents, Plastic Base, Hose / Horn and bracket.

**It includes Empty Extinguisher, Packaging, Contents, Plastic Base, Hose / Horn and bracket.

CERTIFICATIONS



PRODUCT PICTURES



2L

3L

6L

9L

*v2' Published Date is 27-04-2026.

**Regular R&D and product improvisations may lead to change in product specifications in this data sheet, without any prior notice.