

## CEASEFIRE'S AUTOMATIC EXTINGUISHERS AND SYSTEMS

The Ceasefire M Series Automatic extinguishers is a breakthrough range of Wall Mounted and Ceiling Mounted units that are designed for three-fold fire protection of a premises that is Intuitive (Self Activated), Responsive (Monitorable) and Scalable (Expandable).

The Ceasefire M Series extinguishers are Thermally-Actuated extinguishers that come in Wall Mounted and Ceiling Mounted variants and are designed to give 24x7 automatic fire protection to any space.

The modular nature of these extinguishers make them retrofittable and can instantly be mounted in a variety of spaces, making the premises self-reliant on fire safety, without having to undertake any structural changes in the space.

Available in a choice of ABC Power and Clean Agent Fluoroketone (FK-5-1-12), the biggest strength of the Ceasefire Automatic M Series Extinguisher is their ability to become monitorable and scalable by opting for devices such as Pressure Switch, Metron Actuators, Detectors, etc.



*\*All devices shown in the visual above including Metron Actuators, Pressure Switch, Detectors, Siren Strobe, Manual Actuator and Control Panel, are add-on optional devices and not a part of the standard product. These devices need to be ordered separately to configure a flooding system. Designing a total flooding system using M series extinguishers require system manual guidelines to be followed.*

## WALL MOUNTED (PRODUCT OVERVIEW)

The Ceasefire Wall Mounted Automatic M Series Extinguishers are Thermally-Actuated extinguishers and are designed to give 24x7 automatic fire protection to any space where human presence is low or absent and manual fire detection and fire fighting is a challenge.

The modular nature of these extinguishers make them retrofittable and can instantly be mounted in a variety of spaces, making the premises self-reliant on fire safety, without having to undertake any structural changes in the space.

Available in a choice of ABC Power (MAP 50) and Clean Agent Fluoroketone (FK-5-1-12), the biggest strength of the Ceasefire Wall Mounted Automatic M Series Extinguisher however is their ability to become monitorable and scalable.



By opting for a Pressure Switch these extinguishers can be integrated to third-party devices to become monitorable. On the other hand these extinguishers can also be used as building blocks to form a scalable and integrated total flooding solution by opting for Metron Actuators and connecting the units with fire detection devices and a control panel.

## ENGINEERING DRAWINGS

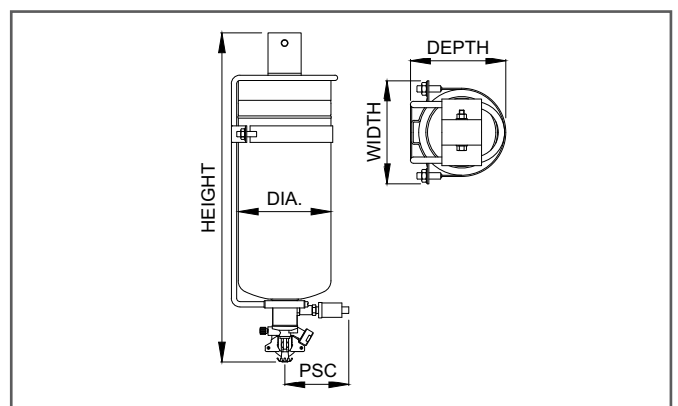
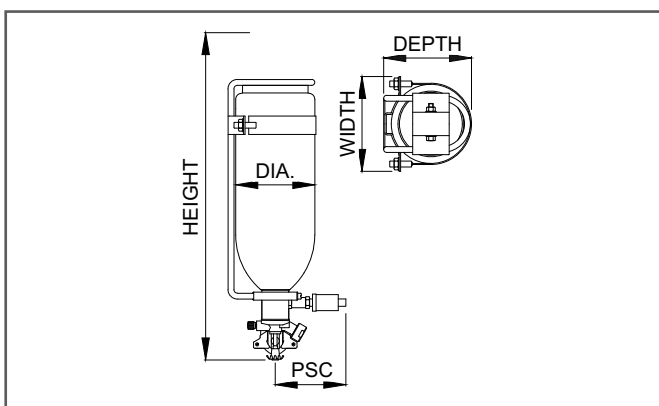

Automatic Fire Ext Wall Mounted MS SP Red						
PRODUCT CODE	SIZE kg	DIA. mm	HEIGHT mm	WIDTH mm	DEPTH mm	PSC mm
CF-001401CT / CF-001411CT	1	108	442	130	119	100
CF-001402CT / CF-001413CT	2	108	442	130	119	100

Automatic Fire Ext Wall Mounted MS SP Red						
PRODUCT CODE	SIZE kg	DIA. mm	HEIGHT mm	WIDTH mm	DEPTH mm	PSC mm
CF-001403C / CF-001415C	4	140	493	162	161	100
CF-001404C / CF-001416C	6	160	538	162	161	100
CF-001405C / CF-001417C	9	175	668	197	198	100

\*The Metron Actuator shown in the product visual above is for representation purpose only. This is an optional device and is not a part of the standard product.



**TECHNICAL SPECIFICATIONS - ABC POWDER MAP50**

Product Code	UOM	CF-001401AT* ●	CF-001402AT* ●	CF-001403A ●	CF-001404A ●	CF-001405A ●
		CF-001401BT* ●	CF-001402BT* ●	CF-001403B ●	CF-001404B ●	CF-001405B ●
		CF-001401CT* ●	CF-001402CT* ●	CF-001403C ●	CF-001404C ●	CF-001405C ●
		CF-001401DT* ●	CF-001402DT* ●	CF-001403D ●	CF-001404D ●	CF-001405D ●
		CF-001401ET* ●	CF-001402ET* ●	CF-001403E ●	CF-001404E ●	CF-001405E ●
Description	—	Automatic Fire Ext Wall Mounted MAP50 1 Kg MS SP Red	Automatic Fire Ext Wall Mounted MAP50 2 Kg MS SP Red	Automatic Fire Ext Wall Mounted MAP50 4 Kg MS SP Red	Automatic Fire Ext Wall Mounted MAP50 6 Kg MS SP Red	Automatic Fire Ext Wall Mounted MAP50 9 Kg MS SP Red
Capacity of Agent	Kg	1	2	4	6	9
Tolerance By Mass	%	± 5%	± 3%	± 2%	± 2%	± 2%
Certification	—	a) PED b) UKCA	a) PED b) UKCA	a) PED b) UKCA	a) PED b) UKCA	a) PED b) UKCA
Agent	—	ABC Powder MAP50	ABC Powder MAP50	ABC Powder MAP50	ABC Powder MAP50	ABC Powder MAP50
Dia of Shell (approx.)	mm	86	108	140	160	175
Total Height (approx.)	mm	370	442	493	538	668
MOC of Shell	—	Steel CR2(DC01)	Steel CR2(DC01)	Steel CR2(DC01)	Steel CR2(DC01)	Steel CR2(DC01)
Min. Wall Thickness	mm	1.4	1.4	1.2	1.4	1.4
Test Pressure	Bar	35	35	35	35	35
Anti Corrosive Treatment	—	Outer surfaces EP Powder coated having Min. Thickness 50 Micron Shade Color Red		Outer surfaces EP Powder coated having Min. Thickness 50 Micron Shade Color Red		
Service Pressure	Bar	15	15	15	15	15



**TECHNICAL SPECIFICATIONS - ABC POWDER MAP50**

<b>Product Code</b>	<b>UOM</b>	CF-001401AT* ●	CF-001402AT* ●	CF-001403A ●	CF-001404A ●	CF-001405A ●
		CF-001401BT* ●	CF-001402BT* ●	CF-001403B ●	CF-001404B ●	CF-001405B ●
		CF-001401CT* ●	CF-001402CT* ●	CF-001403C ●	CF-001404C ●	CF-001405C ●
		CF-001401DT* ●	CF-001402DT* ●	CF-001403D ●	CF-001404D ●	CF-001405D ●
		CF-001401ET* ●	CF-001402ET* ●	CF-001403E ●	CF-001404E ●	CF-001405E ●
<b>Type of Operating Mechanism</b>	—	Automatic Thermal Quarzoid Bulb and Elect (metron)	Automatic Thermal Quarzoid Bulb and Elect (metron)	Automatic Thermal Quarzoid Bulb and Elect (metron)	Automatic Thermal Quarzoid Bulb and Elect (metron)	Automatic Thermal Quarzoid Bulb and Elect (metron)
<b>Type of Pressure Gauge</b>	—	Magnetic Bourdon Tube Type	Magnetic Bourdon Tube Type	Magnetic Bourdon Tube Type	Magnetic Bourdon Tube Type	Magnetic Bourdon Tube Type
<b>Type of Discharge Fitting</b>	mm	Sprinkler With Quartzoid Bulbhead	Sprinkler With Quartzoid Bulbhead	Sprinkler With Quartzoid Bulbhead	Sprinkler With Quartzoid Bulbhead	Sprinkler With Quartzoid Bulbhead
<b>Min. Discharge Time</b>	Sec.	1	1.2	2.5	3.5	5
<b>Maximum Spacing Allowed</b>	m	1.2	1.4	3	4	5
<b>Effective Coverage Area</b>	m <sup>2</sup>	1.5	3	9	12	20
<b>Maximum Ceiling Height</b>	m	0.8	1.4	2.5	3.0	3.5
<b>Operating Temperature Range(approx.)</b>	°C	-30 to 60	-30 to 60	-30 to 60	-30 to 60	-30 to 60
<b>Actuation Temperature**</b>	°C	79 ± 4	79 ± 4	79 ± 4	79 ± 4	79 ± 4
<b>Applicable To Type Of Fire</b>	—	Class A, B, C and Electrical Started Fire	Class A, B, C and Electrical Started Fire	Class A, B, C and Electrical Started Fire	Class A, B, C and Electrical Started Fire	Class A, B, C and Electrical Started Fire
<b>Filled Weight Range***</b>	Kg	1.85 - 1.95	3.8 - 4.3	6.9 - 7.2	9.2 -9.8	13.5 - 14.4
<b>Empty Weight Range</b>	Kg	0.85	1.35	1.95	2.65	3.85
<b>Packed Weight Range (approx.)****</b>	Kg	2.68	4.2	7.45	10.1	15.5



TECHNICAL SPECIFICATIONS - ABC POWDER MAP50

Product Code	UOM	CF-001401AT* ●	CF-001402AT* ●	CF-001403A ●	CF-001404A ●	CF-001405A ●
		CF-001401BT* ●	CF-001402BT* ●	CF-001403B ●	CF-001404B ●	CF-001405B ●
		CF-001401CT* ●	CF-001402CT* ●	CF-001403C ●	CF-001404C ●	CF-001405C ●
		CF-001401DT* ●	CF-001402DT* ●	CF-001403D ●	CF-001404D ●	CF-001405D ●
		CF-001401ET* ●	CF-001402ET* ●	CF-001403E ●	CF-001404E ●	CF-001405E ●
Packing Size Length x Width x Height	mm	125 x 115 x 400	130 x 140 x 415	160 x 160 x 470	175 x 175 x 715	190 x 195 x 650
Product Warranty*****	Year	1	1	1	1	1

\*Comes with Transport Bracket.

\*\*Quartzoid bulb in other temperature settings part from the one highlighted in the box below are available on request and would be dependent on MOQ for your region. Please check the availability and delivery time before ordering.

\*\*\*It includes Empty Extinguisher, Contents and Plastic Base only (where applicable) - not including hose, Wall bracket or Packaging.

\*\*\*\*Includes all packaging, hose / horn and bracket.

\*\*\*\*\*Product warranty would differ for Automatic - M Series Extinguishers and System versions as per the respective product specifications.

QUARTZOID BULB KEY

● 57°C / 135°F
● 68°C / 155°F
● 79°C / 174°F
● 93°C / 200°F
● 141°C / 286°F

CERTIFICATIONS



PRODUCT PICTURES



1 Kg



2 Kg



6 Kg



9 Kg



4 Kg

\*The Metron Actuator shown in the product visual above is for representation purpose only. This is an optional device and is not a part of the standard product.



**TECHNICAL SPECIFICATIONS - FLUOROKETONE (FK-5-1-12)**

Product Code	UOM	CF-001411AT* ●	CF-001413AT* ●	CF-001415A ●	CF-001416A ●	CF-001417A ●
		CF-001411BT* ●	CF-001413BT* ●	CF-001415B ●	CF-001416B ●	CF-001417B ●
		CF-001411CT* ●	CF-001413CT* ●	CF-001415C ●	CF-001416C ●	CF-001417C ●
		CF-001411DT* ●	CF-001413DT* ●	CF-001415D ●	CF-001416D ●	CF-001417D ●
		CF-001411ET* ●	CF-001413ET* ●	CF-001415E ●	CF-001416E ●	CF-001417E ●
<b>Description</b>	—	Automatic Fire Ext Wall Mounted (FK-5-1-12) 1 Kg MS SP Red	Automatic Fire Ext Wall Mounted (FK-5-1-12) 2 Kg MS SP Red	Automatic Fire Ext Wall Mounted (FK-5-1-12) 4 Kg MS SP Red	Automatic Fire Ext Wall Mounted (FK-5-1-12) 6 Kg MS SP Red	Automatic Fire Ext Wall Mounted (FK-5-1-12) 9 Kg MS SP Red
<b>Capacity of Agent</b>	Kg	1	2	4	6	9
<b>Tolerance By Mass</b>	%	+ 5%	+ 5%	+ 5%	+ 5%	+ 5%
<b>Certification</b>	—	a) PED b) UKCA	a) PED b) UKCA	a) PED b) UKCA	a) PED b) UKCA	a) PED b) UKCA
<b>Agent</b>	—	FK-5-1-12	FK-5-1-12	FK-5-1-12	FK-5-1-12	FK-5-1-12
<b>Dia of Shell (approx.)</b>	mm	86	108	140	160	175
<b>Total Height (approx.)</b>	mm	370	442	493	538	668
<b>MOC of Shell</b>	—	Steel CR2(DC01)	Steel CR2(DC01)	Steel CR2(DC01)	Steel CR2(DC01)	Steel CR2(DC01)
<b>Min. Wall Thickness</b>	mm	1.4	1.4	1.2	1.4	1.4
<b>Test Pressure</b>	Bar	30	30	30	30	30
<b>Anti Corrosive Treatment</b>	—	Outer surfaces EP Powder coated having Min. Thickness 50 Micron Shade Color Red		Outer surfaces EP Powder coated having Min. Thickness 50 Micron Shade Color Red		
<b>Service Pressure</b>	Bar	10	10	10	10	10



**TECHNICAL SPECIFICATIONS - FLUOROKETONE (FK-5-1-12)**

Product Code	UOM	CF-001411AT* ●	CF-001413AT* ●	CF-001415A ●	CF-001416A ●	CF-001417A ●
		CF-001411BT* ●	CF-001413BT* ●	CF-001415B ●	CF-001416B ●	CF-001417B ●
		CF-001411CT* ●	CF-001413CT* ●	CF-001415C ●	CF-001416C ●	CF-001417C ●
		CF-001411DT* ●	CF-001413DT* ●	CF-001415D ●	CF-001416D ●	CF-001417D ●
		CF-001411ET* ●	CF-001413ET* ●	CF-001415E ●	CF-001416E ●	CF-001417E ●
Type of Operating Mechanism	—	Automatic Thermal Quarzoid Bulb and Elect (metron)	Automatic Thermal Quarzoid Bulb and Elect (metron)	Automatic Thermal Quarzoid Bulb and Elect (metron)	Automatic Thermal Quarzoid Bulb and Elect (metron)	Automatic Thermal Quarzoid Bulb and Elect (metron)
Type of Pressure Gauge	—	Magnetic Bourdon Tube Type	Magnetic Bourdon Tube Type	Magnetic Bourdon Tube Type	Magnetic Bourdon Tube Type	Magnetic Bourdon Tube Type
Type of Discharge Fitting	mm	Sprinkler With Quartzoid Bulbhead	Sprinkler With Quartzoid Bulbhead	Sprinkler With Quartzoid Bulbhead	Sprinkler With Quartzoid Bulbhead	Sprinkler With Quartzoid Bulbhead
Min. Discharge Time	Sec.	0.5	1	2	3	4
Min Single Volume Coverage	m <sup>3</sup>	0.79	1.58	3.16	4.74	7.11
Max Single Volume Coverage	m <sup>3</sup>	1.4	2.8	5.7	8.5	12.8
Concentration at Max Volume.	m <sup>3</sup>	4.5	4.5	4.5	4.5	4.5
Operating Temperature Range(approx.)	°C	-30 to 60	-30 to 60	-30 to 60	-30 to 60	-30 to 60
Actuation Temperature**	°C	79 ± 4	79 ± 4	79 ± 4	79 ± 4	79 ± 4
Applicable To Type Of Fire	—	Class A, B, C and Electrical Started Fire	Class A, B, C and Electrical Started Fire	Class A, B, C and Electrical Started Fire	Class A, B, C and Electrical Started Fire	Class A, B, C and Electrical Started Fire
Filled Weight Range***	Kg	1.85	3.35	6.05	8.75	12.95
Empty Weight Range	Kg	0.85	1.35	1.95	2.65	3.85
Packed Weight Range (approx.) ****	Kg	2.68	4.2	7.45	10.1	15.5
Packing Size Length x Width x Height	mm	125 x 115 x 400	130 x 140 x 415	160 x 160 x 470	175 x 175 x 715	190 x 195 x 650

TECHNICAL SPECIFICATIONS - FLUOROKETONE (FK-5-1-12)

Product Code	UOM	CF-001411AT* <span style="color: orange;">●</span>	CF-001413AT* <span style="color: orange;">●</span>	CF-001415A <span style="color: orange;">●</span>	CF-001416A <span style="color: orange;">●</span>	CF-001417A <span style="color: orange;">●</span>
		CF-001411BT* <span style="color: red;">●</span>	CF-001413BT* <span style="color: red;">●</span>	CF-001415B <span style="color: red;">●</span>	CF-001416B <span style="color: red;">●</span>	CF-001417B <span style="color: red;">●</span>
		CF-001411CT* <span style="color: yellow;">●</span>	CF-001413CT* <span style="color: yellow;">●</span>	CF-001415C <span style="color: yellow;">●</span>	CF-001416C <span style="color: yellow;">●</span>	CF-001417C <span style="color: yellow;">●</span>
		CF-001411DT* <span style="color: green;">●</span>	CF-001413DT* <span style="color: green;">●</span>	CF-001415D <span style="color: green;">●</span>	CF-001416D <span style="color: green;">●</span>	CF-001417D <span style="color: green;">●</span>
		CF-001411ET* <span style="color: blue;">●</span>	CF-001413ET* <span style="color: blue;">●</span>	CF-001415E <span style="color: blue;">●</span>	CF-001416E <span style="color: blue;">●</span>	CF-001417E <span style="color: blue;">●</span>
Product Warranty*****	Year	1	1	1	1	1

\*Comes with Transport Bracket.

\*\*Quartzoid bulb in other temperature settings part from the one highlighted in the box below are available on request and would be dependent on MOQ for your region. Please check the availability and delivery time before ordering.

\*\*\*It includes Empty Extinguisher, Contents and Plastic Base only (where applicable) - not including hose, Wall bracket or Packaging.

\*\*\*\*Includes all packaging, hose / horn and bracket.

\*\*\*\*\*Product warranty would differ for Automatic - M Series Extinguishers and System versions as per the respective product specifications.

QUARTZOID BULB KEY

<span style="color: orange;">●</span> 57°C / 135°F	<span style="color: red;">●</span> 68°C / 155°F	<span style="color: yellow;">●</span> 79°C / 174°F	<span style="color: green;">●</span> 93°C / 200°F	<span style="color: blue;">●</span> 141°C / 286°F
--	---	--	---	---

CERTIFICATIONS



PRODUCT PICTURES



\*The Metron Actuator and Pressure Switch shown in the product visual above are for representation purpose only. These are optional devices and are not a part of the standard product.

## CEILING MOUNTED (PRODUCT OVERVIEW)

Ceasefire Ceiling Mounted Automatic (M Series) ABC Powder (MAP 90) extinguishers are designed to be - Intuitive (Self Activated), Responsive (Monitorable) and Scalable (Expandable). These are self-contained units with thermal sensors that detect the rise in the temperature of the area and activate automatically.

The modular nature of these extinguishers make them retrofittable and can instantly be mounted in ceiling spaces, without consuming the productive floor space of the premises and without having to undertake any structural changes in the space.

The modular nature of these extinguishers make them retrofittable and can instantly be mounted in ceiling spaces, without consuming the productive floor space of the premises and without having to undertake any structural changes in the space.

By opting for a Pressure Switch these extinguishers can be integrated to third-party devices to become monitorable. On the other hand these extinguishers can also be used as building blocks to form a scalable total flooding solution by opting for Metron Actuators and connecting the units with fire detection devices and a control panel



## ENGINEERING DRAWINGS

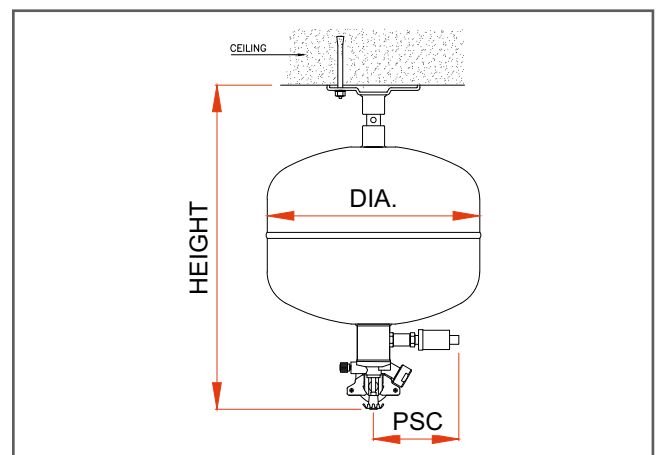
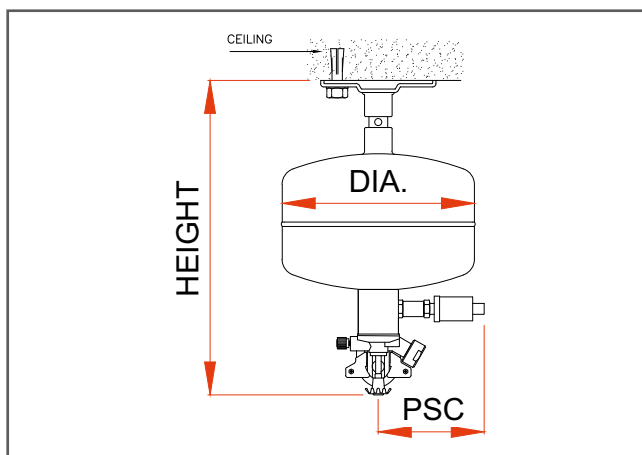

Automatic Fire Ext Ceiling Mounted MS SP Red				
PRODUCT CODE	SIZE kg	DIA. mm	HEIGHT mm	PSC mm
CF-001388B / CF-001393B	2	175	287	100

Automatic Fire Ext Ceiling Mounted MS SP Red				
PRODUCT CODE	SIZE kg	DIA. mm	HEIGHT mm	PSC mm
CF-000017B / CF-001337B	5	240	367	100
CF-000018B / CF-001338B	10	300	389	100
CF-001490B / CF-001493B	15	300	469	100

\*The Metron Actuator and Pressure Switch shown in the product visual above are for representation purpose only. These are optional devices and are not a part of the standard product.



**TECHNICAL SPECIFICATIONS - ABC POWDER MAP90**

Product Code	UOM	CF-001388A ● CF-001388B ● CF-001388C ● CF-001388D ● CF-001388E ●	CF-000017F ● CF-000017B ● CF-000017C ● CF-000017D ● CF-000017E ●	CF-000018F ● CF-000018B ● CF-000018C ● CF-000018D ● CF-000018E ●	CF-001490A ● CF-001490B ● CF-001490C ● CF-001490D ● CF-001490E ●
<b>Description</b>	—	Automatic Fire Ext Ceiling Mounted MAP90 2 Kg MS SP Red	Automatic Fire Ext Ceiling Mounted MAP90 5 Kg MS SP Red	Automatic Fire Ext Ceiling Mounted MAP90 10 Kg MS SP Red	Automatic Fire Ext Ceiling Mounted MAP90 15 Kg MS SP Red
<b>Capacity of Agent</b>	Kg	2	5	10	15
<b>Tolerance By Mass</b>	%	+ 2%	+ 2%	+ 2%	+ 2%
<b>Certification</b>	—	a) PED b) UKCA c) BSI (TESTED)*	a) PED b) UKCA c) BSI (TESTED)	a) PED b) UKCA c) BSI (TESTED)	a) PED b) UKCA c) BSI (TESTED)*
<b>Agent</b>	—	ABC Powder MAP90	ABC Powder MAP90	ABC Powder MAP90	ABC Powder MAP90
<b>Dia of Shell (approx.)</b>	mm	175	240	300	300
<b>Total Height (approx.)</b>	mm	287	367	389	469
<b>MOC of Shell</b>	—	Steel CR2(DC01)	Steel CR2(DC01)	Steel CR2(DC01)	Steel CR2(DC01)
<b>Min. Wall Thickness</b>	mm	2.0	1.6	2.0	2.0
<b>Test Pressure</b>	Bar	35	35	35	35
<b>Anti Corrosive Treatment</b>	—	Outer surfaces EP Powder coated having Min. Thickness 50 Micron Shade Color Red	Outer surfaces EP Powder coated having Min. Thickness 50 Micron Shade Color Red	Outer surfaces EP Powder coated having Min. Thickness 50 Micron Shade Color Red	Outer surfaces EP Powder coated having Min. Thickness 50 Micron Shade Color Red
<b>Service Pressure</b>	Bar	15	15	15	15



**TECHNICAL SPECIFICATIONS - ABC POWDER MAP90**

<b>Product Code</b>	<b>UOM</b>	CF-001388A ● CF-001388B ● CF-001388C ● CF-001388D ● CF-001388E ●	CF-000017F ● CF-000017B ● CF-000017C ● CF-000017D ● CF-000017E ●	CF-000018F ● CF-000018B ● CF-000018C ● CF-000018D ● CF-000018E ●	CF-001490A ● CF-001490B ● CF-001490C ● CF-001490D ● CF-001490E ●
<b>Type of Operating Mechanism</b>	—	Automatic Thermal Quarzoid Bulb and Elect (metron)	Automatic Thermal Quarzoid Bulb and Elect (metron)	Automatic Thermal Quarzoid Bulb and Elect (metron)	Automatic Thermal Quarzoid Bulb and Elect (metron)
<b>Type of Pressure Gauge</b>	—	Magnetic Bourdon Tube Type	Magnetic Bourdon Tube Type	Magnetic Bourdon Tube Type	Magnetic Bourdon Tube Type
<b>Type of Discharge Fitting</b>	mm	Sprinkler With Quartzoid Bulbhead	Sprinkler With Quartzoid Bulbhead	Sprinkler With Quartzoid Bulbhead	Sprinkler With Quartzoid Bulbhead
<b>Min. Discharge Time</b>	Sec.	2 to 5	4 to 8	6 to 10	12 to 18
<b>Maximum Spacing Allowed</b>	m	2.3	2.8	5.5	6.5
<b>Effective Coverage Area</b>	m <sup>2</sup>	5	12.5	25	37.5
<b>Maximum Ceiling Height</b>	m	1.5	3	3.5	4
<b>Operating Temperature Range(approx.)</b>	°C	-30 to 60	-30 to 60	-30 to 60	-30 to 60
<b>Actuation Temperature**</b>	°C	68 ± 4	68 ± 4	68 ± 4	68 ± 4
<b>Applicable To Type Of Fire</b>	—	Class A, B, C & Electrical Started Fire	Class A, B, C & Electrical Started Fire	Class A, B, C & Electrical Started Fire	Class A, B, C & Electrical Started Fire
<b>Filled Weight Range***</b>	Kg	3.85 - 4.10	8.80 - 8.95	15.80 - 16.10	20.60 - 20.80
<b>Packed Weight Range (approx.)****</b>	Kg	1.30	8.80	16.43	20.5 to 20.75
<b>Packing Size Length x Width x Height</b>	mm	230 x 200 x 240	255 x 255 x 320	315 x 315 x 370	360 x 360 x 520

**TECHNICAL SPECIFICATIONS - ABC POWDER MAP90**

Product Code	UOM	CF-001388A ●	CF-000017F ●	CF-000018F ●	CF-001490A ●
		CF-001388B ●	CF-000017B ●	CF-000018B ●	CF-001490B ●
		CF-001388C ●	CF-000017C ●	CF-000018C ●	CF-001490C ●
		CF-001388D ●	CF-000017D ●	CF-000018D ●	CF-001490D ●
		CF-001388E ●	CF-000017E ●	CF-000018E ●	CF-001490E ●
Product Warranty*****	Year	1	1	1	1

\*Co-related from coverage defined for same sizes and agent types verified in Atom X BSI certification.

\*\*Quartzoid bulb in other temperature settings part from the one highlighted in the box below are available on request and would be dependent on MOQ for your region. Please check the availability and delivery time before ordering.

\*\*\*It includes Empty Extinguisher, Contents and Plastic Base only (where applicable) - not including hose, Wall bracket or Packaging.

\*\*\*\*Includes all packaging, hose / horn and bracket.

\*\*\*\*\*Product warranty would differ for Automatic - M Series Extinguishers and System versions as per the respective product specifications.

**QUARTZOID BULB KEY**

● 57°C / 135°F	● 68°C / 155°F	● 79°C / 174°F	● 93°C / 200°F	● 141°C / 286°F
----------------	----------------	----------------	----------------	-----------------

**CERTIFICATIONS**

--	--	--

**PRODUCT PICTURES**





TECHNICAL SPECIFICATIONS - FLUOROKETONE (FK-5-1-12)

Product Code	UOM	CF-001393A ● CF-001393B ● CF-001393C ● CF-001393D ● CF-001393E ●	CF-001337A ● CF-001337B ● CF-001337C ● CF-001337D ● CF-001337E ●	CF-001338A ● CF-001338B ● CF-001338C ● CF-001338D ● CF-001338E ●	CF-001493A ● CF-001493B ● CF-001493C ● CF-001493D ● CF-001493E ●
<b>Description</b>	—	Automatic Fire Ext Ceiling Mounted (FK-5-1-12) 2 Kg MS SP Red	Automatic Fire Ext Ceiling Mounted (FK-5-1-12) 5 Kg MS SP Red	Automatic Fire Ext Ceiling Mounted (FK-5-1-12) 10 Kg MS SP Red	Automatic Fire Ext Ceiling Mounted (FK-5-1-12) 15 Kg MS SP Red
<b>Capacity of Agent</b>	Kg	2	5	10	15
<b>Tolerance By Mass</b>	%	- 5%	- 5%	- 5%	- 5%
<b>Certification</b>	—	a) PED b) UKCA c) BSI (TESTED)	a) PED b) UKCA c) BSI (TESTED)	a) PED b) UKCA c) BSI (TESTED)	a) PED b) UKCA c) BSI (TESTED)
<b>Agent</b>	—	FK-5-1-12	FK-5-1-12	FK-5-1-12	FK-5-1-12
<b>Dia of Shell (approx.)</b>	mm	175	240	300	300
<b>Total Height (approx.)</b>	mm	287	367	389	469
<b>MOC of Shell</b>	—	Steel CR2(DC01)	Steel CR2(DC01)	Steel CR2(DC01)	Steel CR2(DC01)
<b>Min. Wall Thickness</b>	mm	2.0	1.6	2.0	2.0
<b>Test Pressure</b>	Bar	30	30	30	30
<b>Anti Corrosive Treatment</b>	—	Outer surfaces EP Powder coated having Min. Thickness 50 Micron Shade Color Red	Outer surfaces EP Powder coated having Min. Thickness 50 Micron Shade Color Red	Outer surfaces EP Powder coated having Min. Thickness 50 Micron Shade Color Red	Outer surfaces EP Powder coated having Min. Thickness 50 Micron Shade Color Red
<b>Service Pressure</b>	Bar	10	10	10	10



TECHNICAL SPECIFICATIONS - FLUOROKETONE (FK-5-1-12)

Product Code	UOM	CF-001393A ● CF-001393B ● CF-001393C ● CF-001393D ● CF-001393E ●	CF-001337A ● CF-001337B ● CF-001337C ● CF-001337D ● CF-001337E ●	CF-001338A ● CF-001338B ● CF-001338C ● CF-001338D ● CF-001338E ●	CF-001493A ● CF-001493B ● CF-001493C ● CF-001493D ● CF-001493E ●
Type of Operating Mechanism	—	Automatic Thermal Quarzoid Bulb and Elect (metron)	Automatic Thermal Quarzoid Bulb and Elect (metron)	Automatic Thermal Quarzoid Bulb and Elect (metron)	Automatic Thermal Quarzoid Bulb and Elect (metron)
Type of Pressure Gauge	—	Magnetic Bourdon Tube Type	Magnetic Bourdon Tube Type	Magnetic Bourdon Tube Type	Magnetic Bourdon Tube Type
Type of Discharge Fitting	mm	Sprinkler With Quartzoid Bulbhead	Sprinkler With Quartzoid Bulbhead	Sprinkler With Quartzoid Bulbhead	Sprinkler With Quartzoid Bulbhead
Min. Discharge Time	Sec.	2 to 5	4 to 8	6 to 10	6 to 15
Min. Single Volume Coverage	m <sup>3</sup>	1.58	3.95	7.9	11.85
Max. Single Volume Coverage	m <sup>3</sup>	2.8	7.2	14.4	21.5
Concentration at Max Volume.	m <sup>3</sup>	4.5	4.5	4.5	4.5
Operating Temperature Range(approx.)	°C	-30 to 60	-30 to 60	-30 to 60	-30 to 60
Actuation Temperature*	°C	68 ± 4	68 ± 4	68 ± 4	68 ± 4
Applicable To Type Of Fire	—	Class A, B, C and Electrical Started Fire	Class A, B, C and Electrical Started Fire	Class A, B, C and Electrical Started Fire	Class A, B, C and Electrical Started Fire
Filled Weight Range**	Kg	3.95-4.05	7.45 - 7.55	14.10 - 14.55	18.30 - 19.05
Packed Weight Range (approx.)***	Kg	1.30	8.80	16.43	20.5 to 20.75
Packing Size Length x Width x Height	mm	230 x 200 x 240	255 x 255 x 320	315 x 315 x 370	360 x 360 x 520

TECHNICAL SPECIFICATIONS - FLUOROKETONE (FK-5-1-12)

Product Code	UOM	CF-001393A ●	CF-001337A ●	CF-001338A ●	CF-001493A ●
		CF-001393B ●	CF-001337B ●	CF-001338B ●	CF-001493B ●
		CF-001393C ●	CF-001337C ●	CF-001338C ●	CF-001493C ●
		CF-001393D ●	CF-001337D ●	CF-001338D ●	CF-001493D ●
		CF-001393E ●	CF-001337E ●	CF-001338E ●	CF-001493E ●
Product Warranty****	Year	1	1	1	1

\*Quartzoid bulb in other temperature settings part from the one highlighted in the box below are available on request and would be dependent on MOQ for your region. Please check the availability and delivery time before ordering.

\*\*It includes Empty Extinguisher, Contents and Plastic Base only (where applicable) - not including hose, Wall bracket or Packaging.

\*\*\*Includes all packaging, hose / horn and bracket.

\*\*\*\*Product warranty would differ for Automatic - M Series Extinguishers and System versions as per the respective product specifications.

QUARTZOID BULB KEY

● 57°C / 135°F
● 68°C / 155°F
● 79°C / 174°F
● 93°C / 200°F
● 141°C / 286°F

CERTIFICATIONS

PRODUCT PICTURES



## UL & CE CERTIFIED PRESSURE SWITCH (OPTIONAL)

The presence of pressure switch marks the extinguishing units monitorable in nature so the user can always check the system's readiness. The device's role is to convert a mechanical action into an electrical impulse for the control panel to read.



## ENGINEERING DRAWINGS

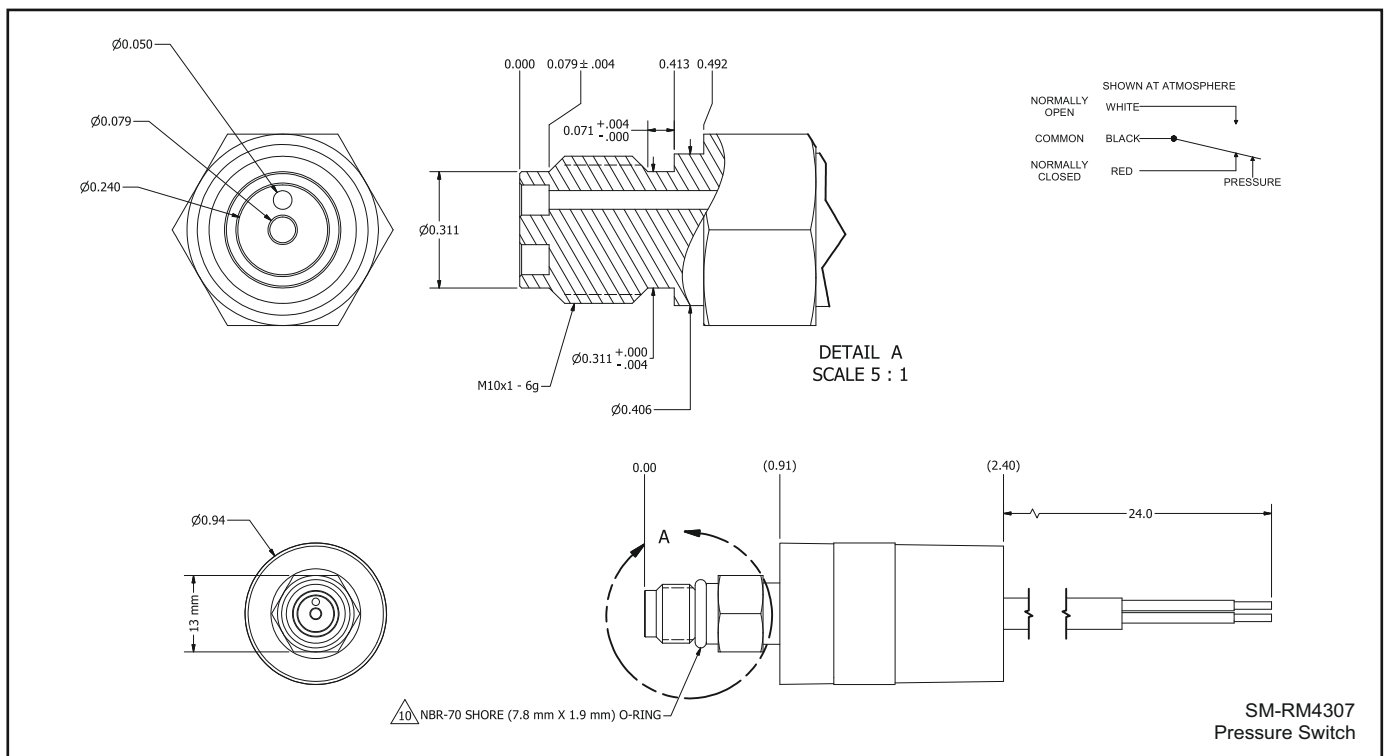

### TECHNICAL SPECIFICATIONS

<b>Product Code</b>	<b>SM-RM4307</b>
<b>Description</b>	Pressure Switch SPDT (Switch Point 5Bar / 72.5 PSIG decreasing) NC & NO -Imp
<b>Increasing Activation</b>	130 PSIG ± 9 PSIG [9 BAR]
<b>Decreasing Activation</b>	72.5 PSIG ± 7 PSIG [5 BAR]
<b>Max Pressure</b>	290 PSIG
<b>Connector</b>	NONE.
<b>Fitting</b>	M10 WITH DEFLATOR.
<b>Fitting Material</b>	BRASS.
<b>Body Material</b>	PLASTIC
<b>Electrical Rating</b>	3A 240 VAC/28 VDC.
<b>Wire Jacket/insulator Material</b>	PVC
<b>O-ring Provided With Switch</b>	NBR-70 SHORE (7.8X1.9 mm)
<b>Certification</b>	UL, RoHS, CE

## UL & CE CERTIFIED METRON ACTUATOR (OPTIONAL)

This is an essential device required to configure a total flooding system using M-Series Extinguishers. The metron actuator receives an electrical impulse from the panel and fires a metal pin inside the actuator that breaks the glass vial placed at the discharge point of M-Series extinguishers.

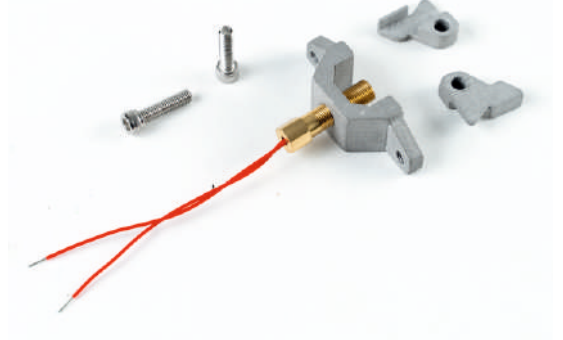

## ENGINEERING DRAWINGS

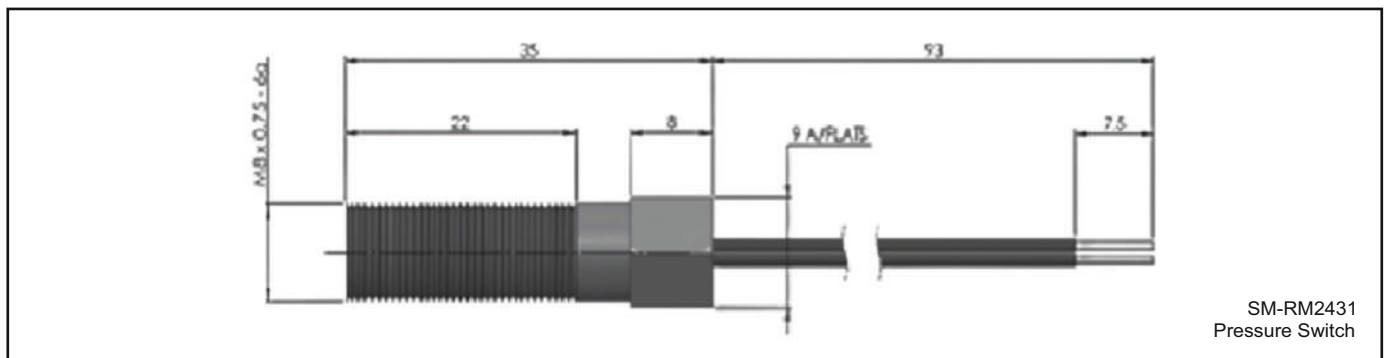

### TECHNICAL SPECIFICATIONS

Nomenclature	UOM	Technical Detail	
Description	-	Metron Actuator For Ceiling or Wall Mounted Atom X Pro	
Product Code	-	SM-RM-2431	
Minimum Piston Stroke Length (mm)	(mm)	9.5	
Body/Piston Material	-	Brass/Stainless Steel	
Minimum Work Output (Joules)	Joules	4.9	
Typical Peak Thrust (Newton's)	Newton's	1800	
Service Life (Ambient) (Years)	-Years	10	
Operating Temperature (OC)	OC)	-40 to +70	
Electrical Resistance Range (Ohms)	Ohms	0.9 - 1.6	
Maximum No Fire Current (Amps)	30 sec pulse	Amps	0.15
	0.05 sec pulse		0.3
Minimum Single Fire Current (Amps)	DC	Amps	0.6
	0.01 sec pulse		0.9
Recommended Series Firing Current (Amps)	Amps	3	
Maximum distance of Metron head from the QBD	mm	7	
Merton Threads on body	-	M 8 X 0.75	

## CONTROL PANEL (OPTIONAL)

This Extinguishing Panel is more than just an alarming solution. These panels are engineered for monitoring, detection, alarm as well as active extinguishing.



### TECHNICAL SPECIFICATIONS

<b>Spare Part Code</b>	TI-002341
<b>Base technology</b>	Flash-based processor
<b>Display</b>	Backlit 128 x 64 LCD
<b>Remote status indicators</b>	Supported via RS485 (maximum of 7)
<b>Controls</b>	Alphanumeric keypad, navigation keys and system keys for Reset, Mute, Silence/Resound and Sound alarms
<b>Detection zones</b>	3 x conventional detection zones (inc. support for I.S. barrier)
<b>Extinguishing Zones</b>	1 x flooding/extinguishing zones. Support for solenoid and metron type actuators
<b>Onboard sounder circuits</b>	3 x 700mA, 21-28VDC
<b>Onboard relays</b>	4 x 1A, 30VDC relay outputs (Fire, Fault & 2 x programmable)
<b>Auxilliary supply</b>	2 x 400mA aux supply outputs 21-28VDC (1 switched)
<b>Programmable outputs</b>	Support for 8 additional programmable outputs via Exp-008
<b>Switch inputs</b>	4 x programmable, 1 x manual trigger, 6 x release related (Mode Select, Valve Monitor, Pressure Monitor, Hold, Abort, Flow)
<b>Countdown timer</b>	On board, large digit
<b>Mains supply</b>	3A universal switch mode PSU
<b>Battery capacity</b>	24V 7Ah
<b>Charger current</b>	1A
<b>USB ports</b>	1 x USB port for PC connection
<b>Event log</b>	1000 event time-stamped
<b>Enclosure, colour</b>	Steel IP30, grey RAL7035
<b>Cable entry</b>	17 knockouts in enclosure top, 13 in enclosure back
<b>Size (H x W x D)</b>	330mm x 400mm x 95mm
<b>Weight</b>	6Kg

## CONVENTIONAL WALL SOUNDER WITH BEACON (OPTIONAL)

Ceasefire's Conventional Wall Sounders with Beacon give out an audio-visual alarm in response to a fire episode. Two modes of alarm ensure that a fire episode never goes un-noticed.



## ENGINEERING DRAWINGS

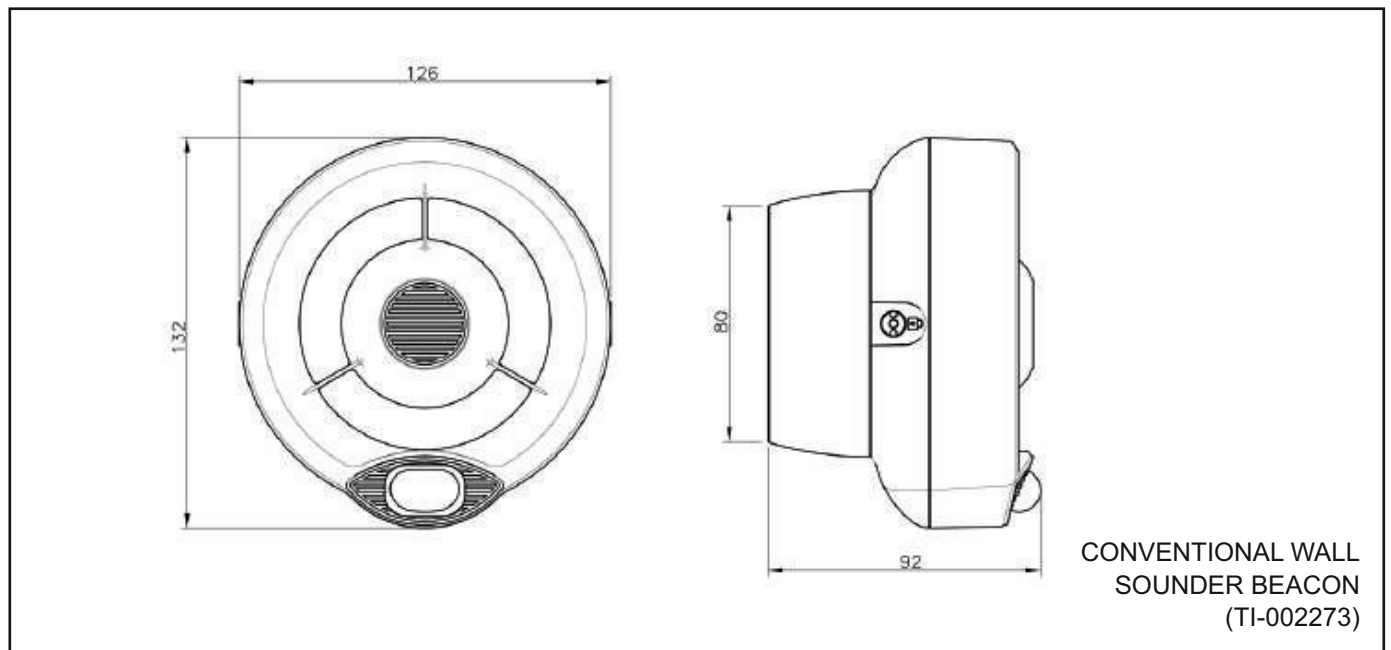

### TECHNICAL SPECIFICATIONS

<b>Spare Part Code</b>	TI-002273
<b>Power supply voltage range</b>	15Vdc - 40Vdc
<b>Activated current load (High Vol.)</b>	11-25 mA at 24 Vdc
<b>Acoustic Frequency range</b>	400-2900 Hz
<b>Maximum acoustic Output</b>	100 dB(A) @ 1m
<b>Visual Alarm Device Frequency</b>	0.5 Hz or 1 Hz
<b>EN54-23 Classification</b>	W-2.5-7
<b>Temperature range (no icing)</b>	-25°C to +70°C
<b>Unit weight (inc Back box)</b>	290g
<b>Max humidity (non condensing)</b>	95% RH
<b>Ingress Protection</b>	IP 65

## ABORT SWITCH (OPTIONAL)

The Abort Switch compatible with the Rapid-Sense gas extinguishing panel and remote status indicator panel input circuits. The switches are easy to wire and multiple units can easily be daisy-chained together on an input circuit.



### TECHNICAL SPECIFICATIONS

<b>Spare Part Code</b>	TI-002342
<b>Dimensions (Plastic Unit)</b>	Overall 87mm x 87mm x 41mm, Back box 87mm x 87mm x 29mm
<b>Dimensions (Metal Trim Unit)</b>	Overall 87mm x 87mm x 47mm, Back box 87mm x 87mm x 44mm
<b>Minimum depth behind cover</b>	35mm
<b>Dimensions (IP65 Unit)</b>	Overall 72 x 72 x 62 (including switch actuator)
<b>Environmental Class</b>	Indoor 0°C to 40°C
<b>Humidity</b>	95% max
<b>End-of-Line Resistance</b>	6800 Ohms
<b>Maximum Operating Voltage</b>	30VDC
<b>SW#1 Active Resistance</b>	470 Ohms



## CONVENTIONAL OPTICAL SMOKE DETECTOR (OPTIONAL)

Ceasefire's Optical Detectors work on the principle of Tyndall effect. The smoke detectors samples the air in the protected area & provide early signs of warning with high levels of accuracy.



### ENGINEERING DRAWINGS

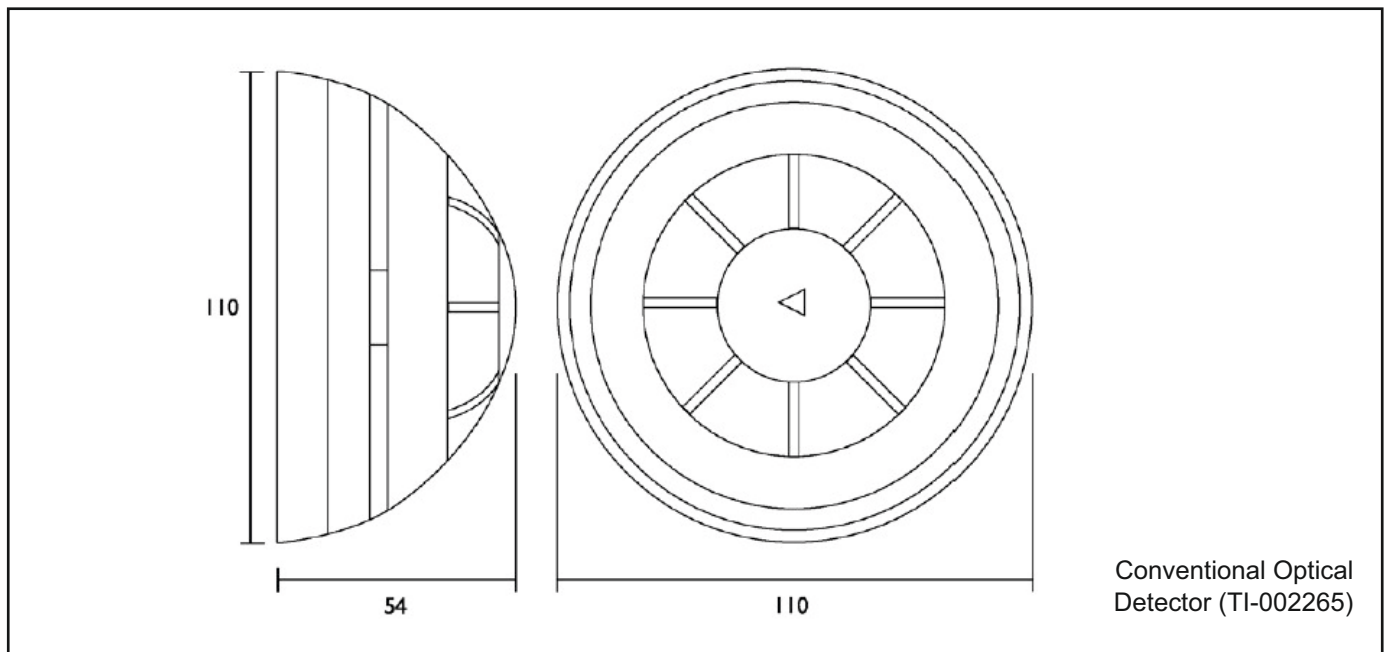

### TECHNICAL SPECIFICATIONS

<b>Spare Part Code</b>	TI-002265
<b>Power supply</b>	10-30 Vdc
<b>Average standby current</b>	90 $\mu$ A @ 24 Vdc
<b>Max alarm current</b>	40 mA
<b>Max remote output current</b>	18 mA
<b>Dimensions</b>	110mm x 54mm
<b>Weight (with base)</b>	190g
<b>Operating Temperature (no icing)</b>	-10°C to +55°C
<b>Max Humidity (non condensing)</b>	95% RH
<b>Heat alarm threshold (class A1R)</b>	58°C
<b>High temp. mode alarm threshold (class B)</b>	78°C
<b>IP rating</b>	40

## CONVENTIONAL THERMAL DETECTOR (OPTIONAL)

Ceasefire's Thermal Detectors check and report any temperature variation in the protected area. These detectors can be deployed as A1R (58oC fixed alarm or 14oC RoR) or Class B (78oC fixed alarm, 25oC RoR) detectors.



Thermal Detector  
(TI-002267 / TI-002268)

### TECHNICAL SPECIFICATIONS

<b>Spare Product Code</b>	TI-002267 / TI-002268
<b>Alarm Temperature</b>	78oC (Class BS)
<b>Operating Voltage</b>	10-30V DC
<b>Standby Current Consumption</b>	90µA @ 24V DC
<b>Max. Alarm Current Consumption</b>	40mA
<b>Max. Remote Output Current</b>	18mA
<b>Ambient Temperature</b>	-10°C to +55°C
<b>Relative Humidity</b>	95% (non condensing)
<b>Dimensions (Diameter x Height)</b>	110mm (Ø) x 54mm (depth)
<b>Standard</b>	EN 54-7
<b>LED Indicator</b>	—
<b>Certification/Approval Authority</b>	LPCB
<b>Protection Class</b>	Ip40

## DETECTOR BASE (OPTIONAL)

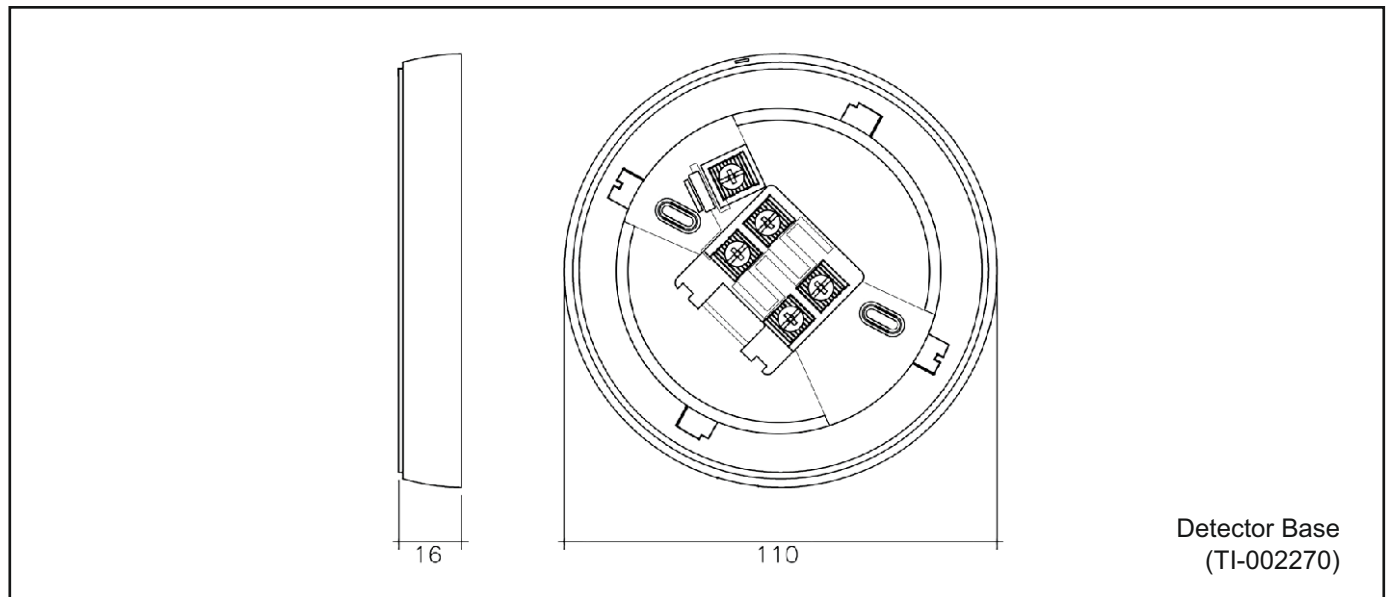

### TECHNICAL SPECIFICATIONS

<b>Spare Part Code</b>	TI-002270
<b>Dimensions</b>	110mm x 16mm
<b>Weight</b>	50g
<b>Temperature Range (no icing)</b>	-10°C to +55°C
<b>Max humidity (non condensing)</b>	95% RH
<b>Cable size</b>	6mA @ 24Vdc



\*v1' Published Date is 30-05-2026.

\*\*Regular R&D and product improvisations may lead to change in product specifications in this data sheet, without any prior notice.